

RECOMMENDED

INNER SLIDE MEMBER:

#10 MACHINE OR WOOD PAN HEAD SCREW FOR ALL THRU HOLES AND SLOTTED THRU HOLES

OUTER SLIDE MEMBER:

#10 MACHINE OR WOOD FLAT HEAD SCREW FOR ALL THRU HOLES AND SLOTTED THRU HOLES

NOTES:

- 1.) DO NOT SCALE DRAWING.
- 2.) REMOVE ALL BURRS, NO SHARP EDGES.
- 3.) MUST NOT HAVE SCRATCHES, DINGS, OR DENTS.
- 4.) PART TO BE FREE FROM SURFACE IMPERFECTIONS OTHER THAN SURFACE FINISH REQUIREMENTS.
- 5.) CRITICAL DIMENSIONS ARE INDICATED BY:
- 6.) ALL ITEMS ARE TO BE INSPECTED TO 2.5 AQL SAMPLING PLAN UNLESS OTHERWISE STATED.
- 7.) ENSURE PACKAGING WILL PROVIDE ADEQUATE PROTECTION DURING TRANSPORT.
- 8.) GEOMETRIC FEATURES NOT DIMENSIONED ARE CONTROLLED BY 3D MODEL.

THE INFORMATION CONTAINED IN THIS DRAWING IS THE SOLE PROPERTY OF RYADON INC. ANY REPRODUCTION IN PART OR AS A WHOLE WITHOUT THE WRITTEN PERMISSION OF RYADON INC. IS PROHIBITED.

REVISIONS			DEPT.	NAME	DATE
REV.	DESCRIPTION	DATE	SALES	FB	3/18/16
A	INITIAL RELEASE	02/26/15	ENG.	KS	3/18/16
			Q.A.	AH	3/18/16
TOLERANCES UNLESS OTHERWISE SPECIFIED: .X = ± .05 .XX = ± .01 .XXX = ± .015 X/X = ± 1/32" ANGLE = ± 1° SURFACE = ± √.125			RYADON INC.		
DESCRIPTION: 2250 SERIES 8" SLIDE			SIZE A	PART No. I-DS-2250-8	REV A
MATERIAL: STEEL			FINISH: ZINC PLATED		
SCALE: NTS			SHEET 1 OF 1		DRAWN BY/DATE KAS 02/26/15

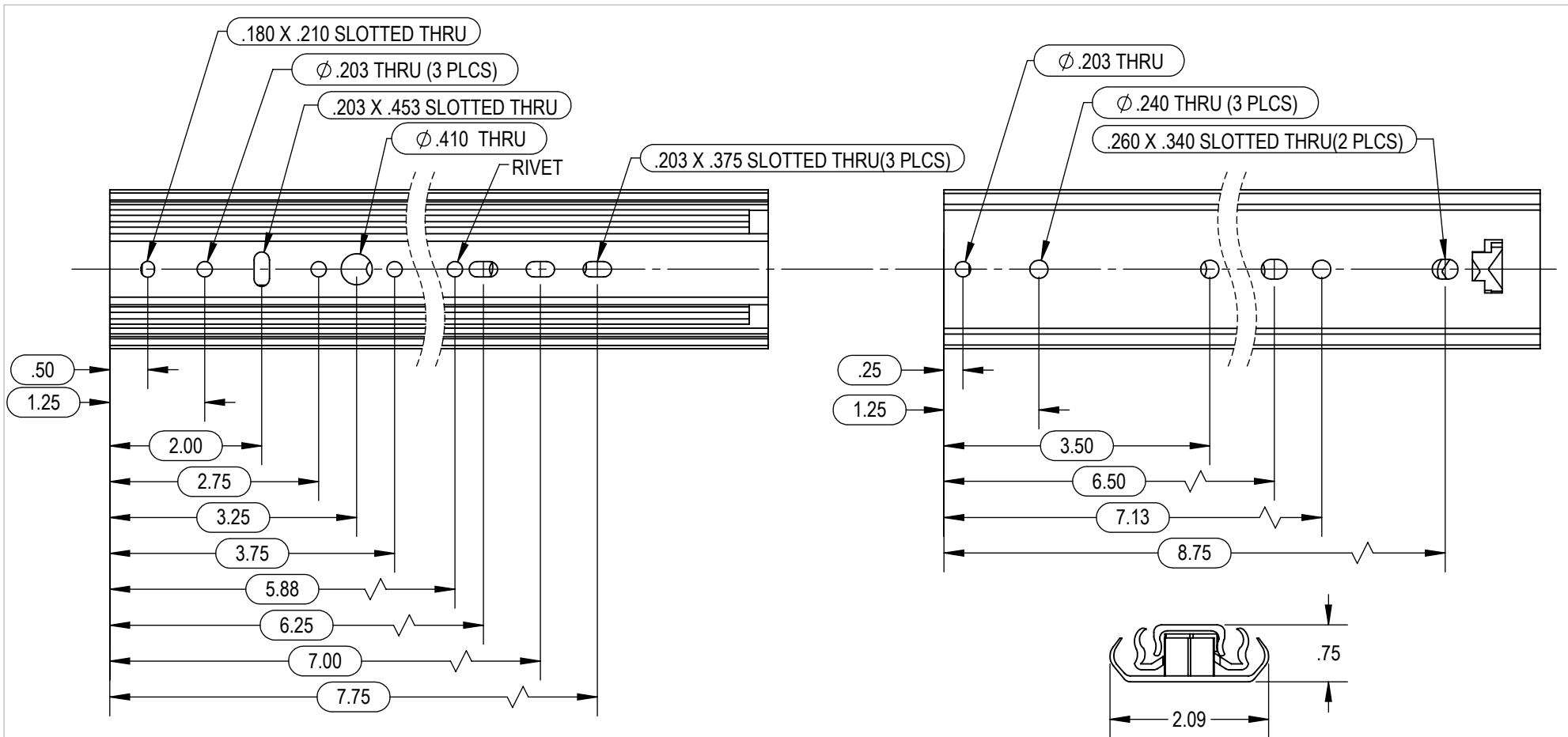

RECOMMENDED
 INNER SLIDE MEMBER:
 #10 MACHINE OR WOOD PAN HEAD SCREW FOR ALL THRU HOLES AND SLOTTED THRU HOLES

OUTER SLIDE MEMBER:
 1/4 HEX BOLT, #14 PAN HEAD WOOD SCREW FOR ALL THRU HOLES AND SLOTTED THRU HOLES

NOTES:

- 1.) DO NOT SCALE DRAWING.
- 2.) REMOVE ALL BURRS, NO SHARP EDGES.
- 3.) MUST NOT HAVE SCRATCHES, DINGS, OR DENTS.
- 4.) PART TO BE FREE FROM SURFACE IMPERFECTIONS OTHER THAN SURFACE FINISH REQUIREMENTS.
- 5.) CRITICAL DIMENSIONS ARE INDICATED BY:
- 6.) ALL ITEMS ARE TO BE INSPECTED TO 2.5 AQL SAMPLING PLAN UNLESS OTHERWISE STATED.
- 7.) ENSURE PACKAGING WILL PROVIDE ADEQUATE PROTECTION DURING TRANSPORT.
- 8.) GEOMETRIC FEATURES NOT DIMENSIONED ARE CONTROLLED BY 3D MODEL.

THE INFORMATION CONTAINED IN THIS DRAWING IS THE SOLE PROPERTY OF RYADON INC. ANY REPRODUCTION IN PART OR AS A WHOLE WITHOUT THE WRITTEN PERMISSION OF RYADON INC. IS PROHIBITED.

REVISIONS			DEPT.	NAME	DATE
REV.	DESCRIPTION	DATE	SALES	FB	3/18/16
A	INITIAL RELEASE	02/26/15	ENG.	KS	3/18/16
			Q.A.	AH	3/18/16
TOLERANCES UNLESS OTHERWISE SPECIFIED: .X = ± .05 .XX = ± .01 .XXX = ± .008 X/X = ± 1/32" ANGLE = ± 1° SURFACE = ± $\sqrt{.125}$			RYADON INC.		
DESCRIPTION: 2250 SERIES 10" SLIDE			SIZE	PART No.	REV
MATERIAL: STEEL			A	I-DS-2250-10-QD	A
FINISH: ZINC PLATED			SCALE: NTS	SHEET 1 OF 1	DRAWN BY/DATE KAS 02/26/15

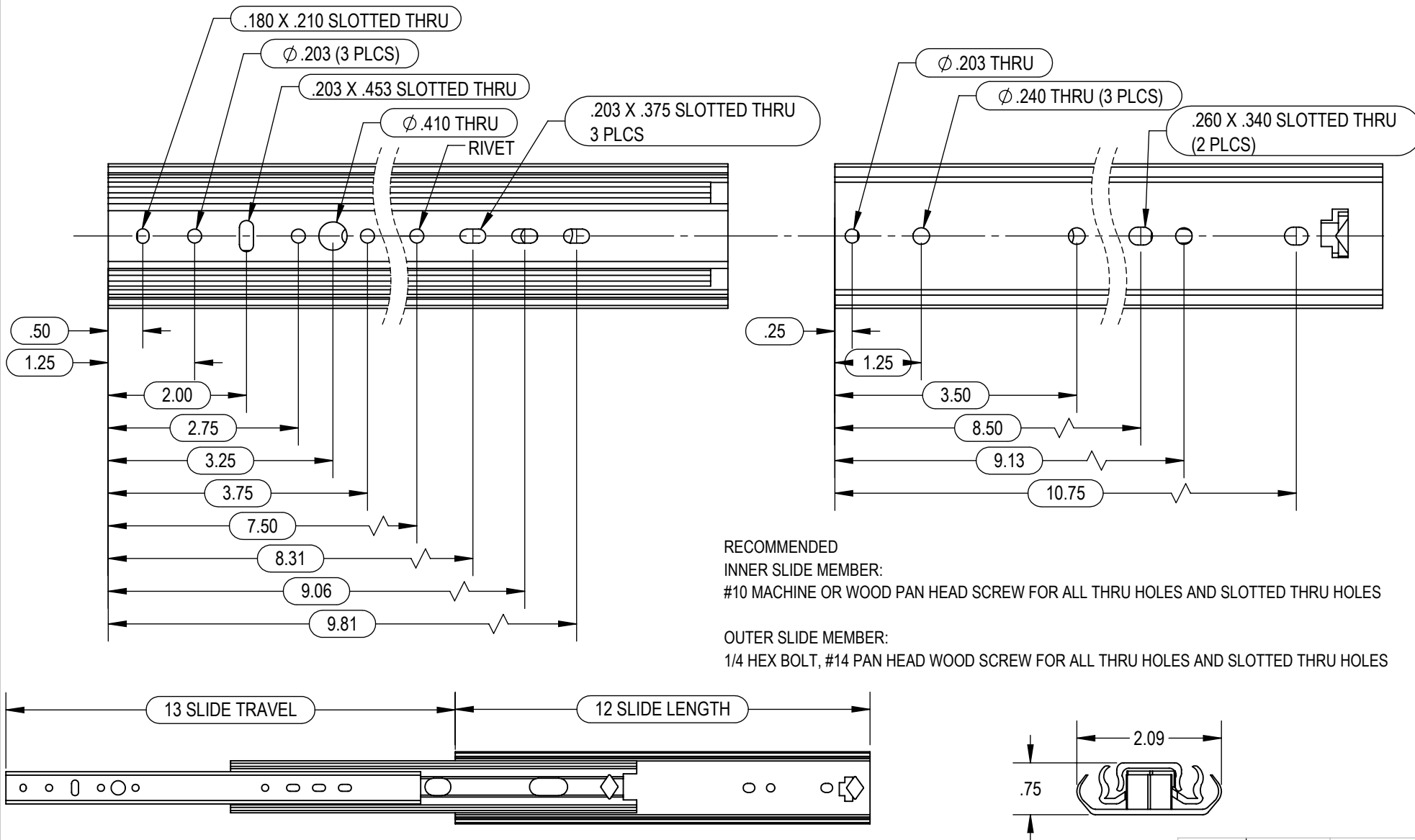

RECOMMENDED
 INNER SLIDE MEMBER:
 #10 MACHINE OR WOOD PAN HEAD SCREW FOR ALL THRU HOLES AND SLOTTED THRU HOLES

OUTER SLIDE MEMBER:
 1/4 HEX BOLT, #14 PAN HEAD WOOD SCREW FOR ALL THRU HOLES AND SLOTTED THRU HOLES

- NOTES:**
- 1.) DO NOT SCALE DRAWING.
 - 2.) REMOVE ALL BURRS, NO SHARP EDGES.
 - 3.) MUST NOT HAVE SCRATCHES, DINGS, OR DENTS.
 - 4.) PART TO BE FREE FROM SURFACE IMPERFECTIONS OTHER THAN SURFACE FINISH REQUIREMENTS.
 - 5.) CRITICAL DIMENSIONS ARE INDICATED BY:
 - 6.) ALL ITEMS ARE TO BE INSPECTED TO 2.5 AQL SAMPLING PLAN UNLESS OTHERWISE STATED.
 - 7.) ENSURE PACKAGING WILL PROVIDE ADEQUATE PROTECTION DURING TRANSPORT.
 - 8.) GEOMETRIC FEATURES NOT DIMENSIONED ARE CONTROLLED BY 3D MODEL.

THE INFORMATION CONTAINED IN THIS DRAWING IS THE SOLE PROPERTY OF RYADON INC. ANY REPRODUCTION IN PART OR AS A WHOLE WITHOUT THE WRITTEN PERMISSION OF RYADON INC. IS PROHIBITED.

REVISIONS			DEPT.	NAME	DATE
REV.	DESCRIPTION	DATE	SALES	FB	3/18/16
A	INITIAL RELEASE	02/26/15	ENG.	KS	3/18/16
			Q.A.	AH	3/18/16
TOLERANCES UNLESS OTHERWISE SPECIFIED: .X = ± .05 .XX = ± .01 .XXX = ± .008 X/X = ± 1/32" ANGLE = ± 1° SURFACE = ± $\sqrt{.125}$			RYADON INC.		
DESCRIPTION: 2250 SERIES 12" SLIDE			SIZE A	PART No. I-DS-2250-12-QD	REV A
MATERIAL: STEEL			SCALE: NTS		
FINISH: ZINC PLATED			SHEET 1 OF 1		
			DRAWN BY/DATE KAS 02/26/15		

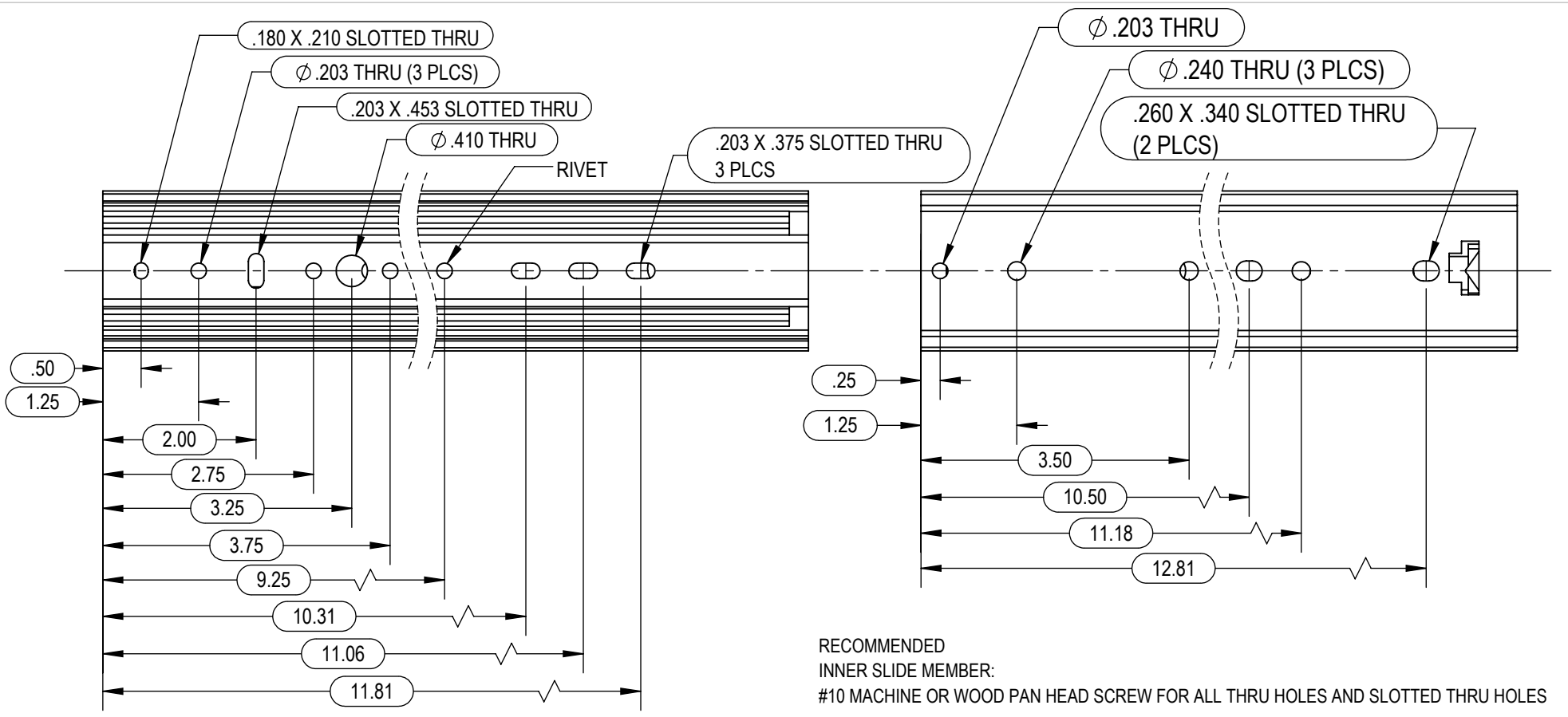

RECOMMENDED
INNER SLIDE MEMBER:
#10 MACHINE OR WOOD PAN HEAD SCREW FOR ALL THRU HOLES AND SLOTTED THRU HOLES

OUTER SLIDE MEMBER:
1/4 HEX BOLT, #14 PAN HEAD WOOD SCREW FOR ALL THRU HOLES AND SLOTTED THRU HOLES

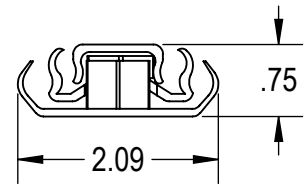
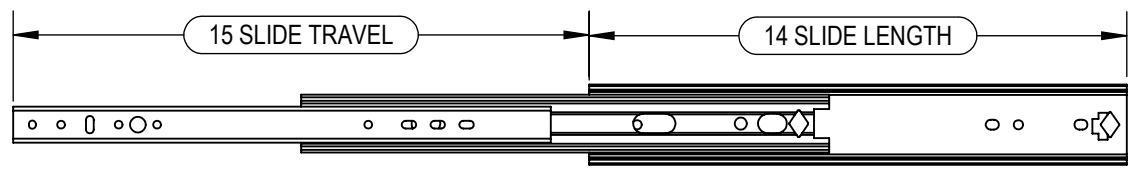

- NOTES:**
- 1.) DO NOT SCALE DRAWING.
 - 2.) REMOVE ALL BURRS, NO SHARP EDGES.
 - 3.) MUST NOT HAVE SCRATCHES, DINGS, OR DENTS.
 - 4.) PART TO BE FREE FROM SURFACE IMPERFECTIONS OTHER THAN SURFACE FINISH REQUIREMENTS.
 - 5.) CRITICAL DIMENSIONS ARE INDICATED BY:
 - 6.) ALL ITEMS ARE TO BE INSPECTED TO 2.5 AQL SAMPLING PLAN UNLESS OTHERWISE STATED.
 - 7.) ENSURE PACKAGING WILL PROVIDE ADEQUATE PROTECTION DURING TRANSPORT.
 - 8.) GEOMETRIC FEATURES NOT DIMENSIONED ARE CONTROLLED BY 3D MODEL.

THE INFORMATION CONTAINED IN THIS DRAWING IS THE SOLE PROPERTY OF RYADON INC. ANY REPRODUCTION IN PART OR AS A WHOLE WITHOUT THE WRITTEN PERMISSION OF RYADON INC. IS PROHIBITED.

REVISIONS			DEPT.	NAME	DATE
REV.	DESCRIPTION	DATE	SALES	FB	3/18/16
A	INITIAL RELEASE	02/26/15	ENG.	KS	3/18/16
			Q.A.	AH	3/18/16

TOLERANCES UNLESS OTHERWISE SPECIFIED: .X = ± .05 .XX = ± .01 .XXX = ± .008 X/X = ± 1/32" ANGLE = ± 1° SURFACE = ± $\sqrt{.125}$		DESCRIPTION: 2250 SERIES 14" SLIDE	RYADON INC.		
MATERIAL:	STEEL	SIZE A	PART No. I-DS-2250-14-QD	REV A	
FINISH:	ZINC PLATED	SCALE: NTS	SHEET 1 OF 1	DRAWN BY/DATE	KAS 02/26/15

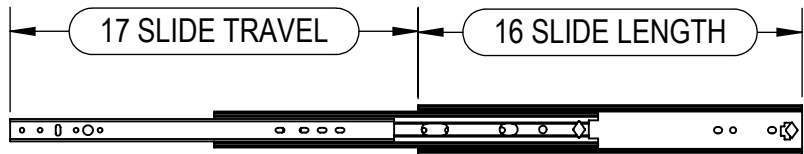
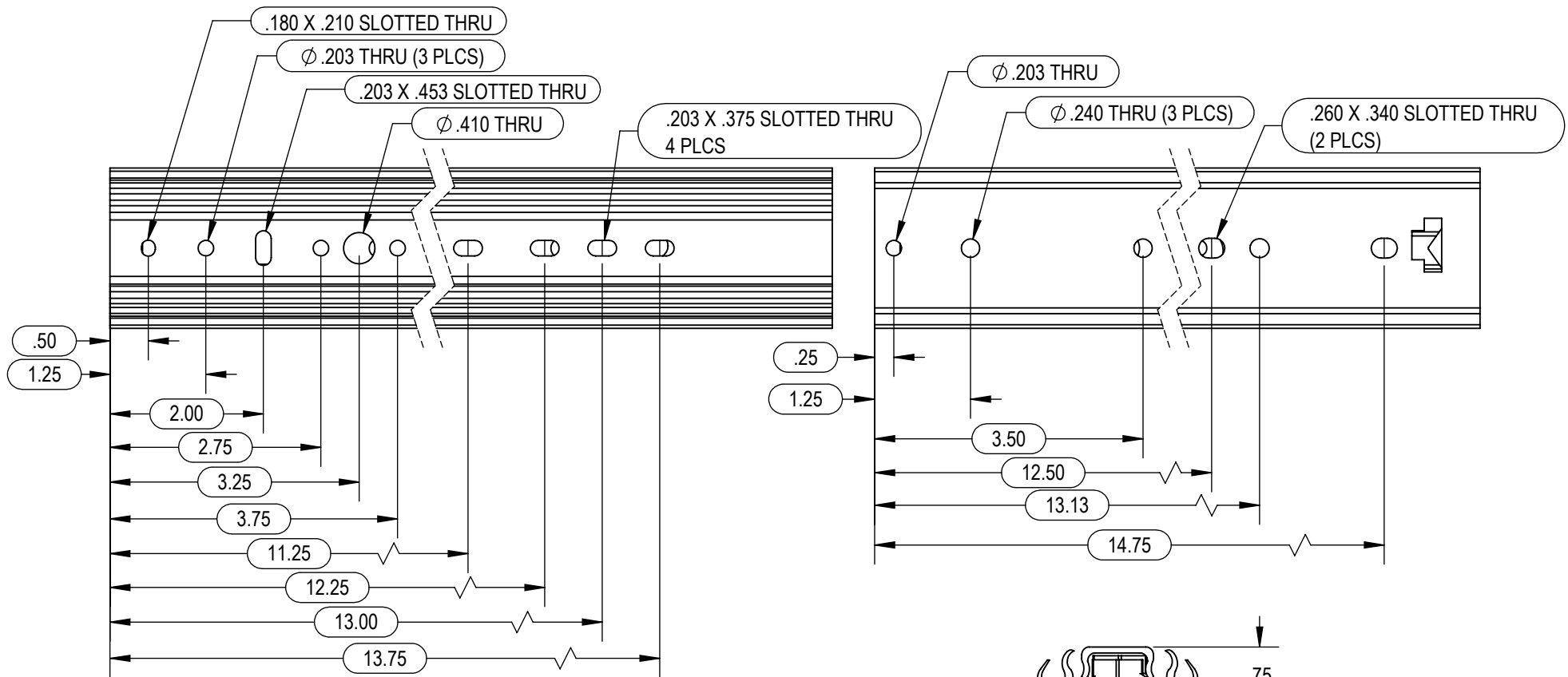

RECOMMENDED

INNER SLIDE MEMBER:

#10 MACHINE OR WOOD PAN HEAD SCREW FOR ALL THRU HOLES AND SLOTTED THRU HOLES

OUTER SLIDE MEMBER:

1/4 HEX BOLT, #14 PANHEAD WOOD SCREW FOR ALL THRU HOLES AND SLOTTED THRU HOLES

NOTES:

- 1.) DO NOT SCALE DRAWING.
- 2.) REMOVE ALL BURRS, NO SHARP EDGES.
- 3.) MUST NOT HAVE SCRATCHES, DINGS, OR DENTS.
- 4.) PART TO BE FREE FROM SURFACE IMPERFECTIONS OTHER THAN SURFACE FINISH REQUIREMENTS.
- 5.) CRITICAL DIMENSIONS ARE INDICATED BY:
- 6.) ALL ITEMS ARE TO BE INSPECTED TO 2.5 AQL SAMPLING PLAN UNLESS OTHERWISE STATED.
- 7.) ENSURE PACKAGING WILL PROVIDE ADEQUATE PROTECTION DURING TRANSPORT.
- 8.) GEOMETRIC FEATURES NOT DIMENSIONED ARE CONTROLLED BY 3D MODEL.

THE INFORMATION CONTAINED IN THIS DRAWING IS THE SOLE PROPERTY OF RYADON INC. ANY REPRODUCTION IN PART OR AS A WHOLE WITHOUT THE WRITTEN PERMISSION OF RYADON INC. IS PROHIBITED.

REVISIONS			DEPT.	NAME	DATE
REV.	DESCRIPTION	DATE	SALES	FB	3/18/16
A	INITIAL RELEASE	02/26/15	ENG.	KS	3/18/16
			Q.A.	AH	3/18/16
TOLERANCES UNLESS OTHERWISE SPECIFIED: .X = ± .05 .XX = ± .01 .XXX = ± .008 X/X = ± 1/32" ANGLE = ± 1° SURFACE = ± $\sqrt{.125}$			DESCRIPTION: 2250 SERIES 16" SLIDE RYADON INC.		
MATERIAL: STEEL FINISH: ZINC PLATED			SIZE A	PART No. I-DS-2250-16-QD	REV A
SCALE: NTS			SHEET 1 OF 1		DRAWN BY/DATE KAS 02/26/15

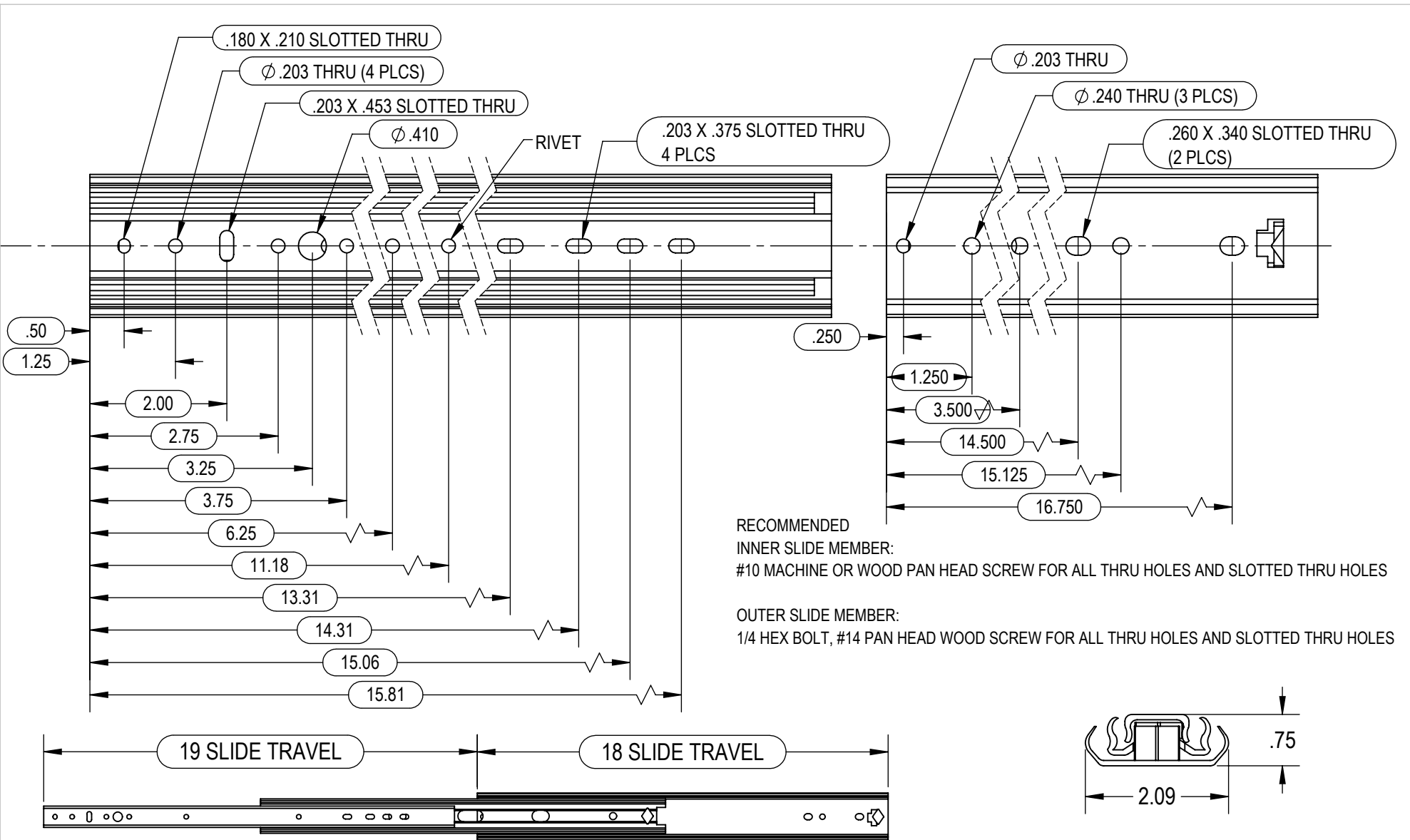

RECOMMENDED
INNER SLIDE MEMBER:
#10 MACHINE OR WOOD PAN HEAD SCREW FOR ALL THRU HOLES AND SLOTTED THRU HOLES

OUTER SLIDE MEMBER:
1/4 HEX BOLT, #14 PAN HEAD WOOD SCREW FOR ALL THRU HOLES AND SLOTTED THRU HOLES

NOTES:

- 1.) DO NOT SCALE DRAWING.
- 2.) REMOVE ALL BURRS, NO SHARP EDGES.
- 3.) MUST NOT HAVE SCRATCHES, DINGS, OR DENTS.
- 4.) PART TO BE FREE FROM SURFACE IMPERFECTIONS OTHER THAN SURFACE FINISH REQUIREMENTS.
- 5.) CRITICAL DIMENSIONS ARE INDICATED BY:
- 6.) ALL ITEMS ARE TO BE INSPECTED TO 2.5 AQL SAMPLING PLAN UNLESS OTHERWISE STATED.
- 7.) ENSURE PACKAGING WILL PROVIDE ADEQUATE PROTECTION DURING TRANSPORT.
- 8.) GEOMETRIC FEATURES NOT DIMENSIONED ARE CONTROLLED BY 3D MODEL.

THE INFORMATION CONTAINED IN THIS DRAWING IS THE SOLE PROPERTY OF RYADON INC. ANY REPRODUCTION IN PART OR AS A WHOLE WITHOUT THE WRITTEN PERMISSION OF RYADON INC. IS PROHIBITED.

REVISIONS			DEPT.	NAME	DATE
REV.	DESCRIPTION	DATE	SALES	FB	3/18/16
A	INITIAL RELEASE	02/26/15	ENG.	KS	3/18/16
			Q.A.	AH	3/18/16
TOLERANCES UNLESS OTHERWISE SPECIFIED: .X = ± .05 .XX = ± .01 .XXX = ± .008 X/X = ± 1/32" ANGLE = ± 1° SURFACE = ± $\sqrt{.125}$			RYADON INC. 		
MATERIAL: STEEL			SIZE A	PART No. I-DS-2250-18-QD	
FINISH: ZINC PLATED			SCALE: NTS	SHEET 1 OF 1	
			REV A	DRAWN BY/DATE KAS 02/26/15	

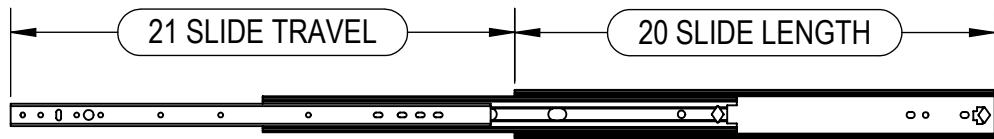
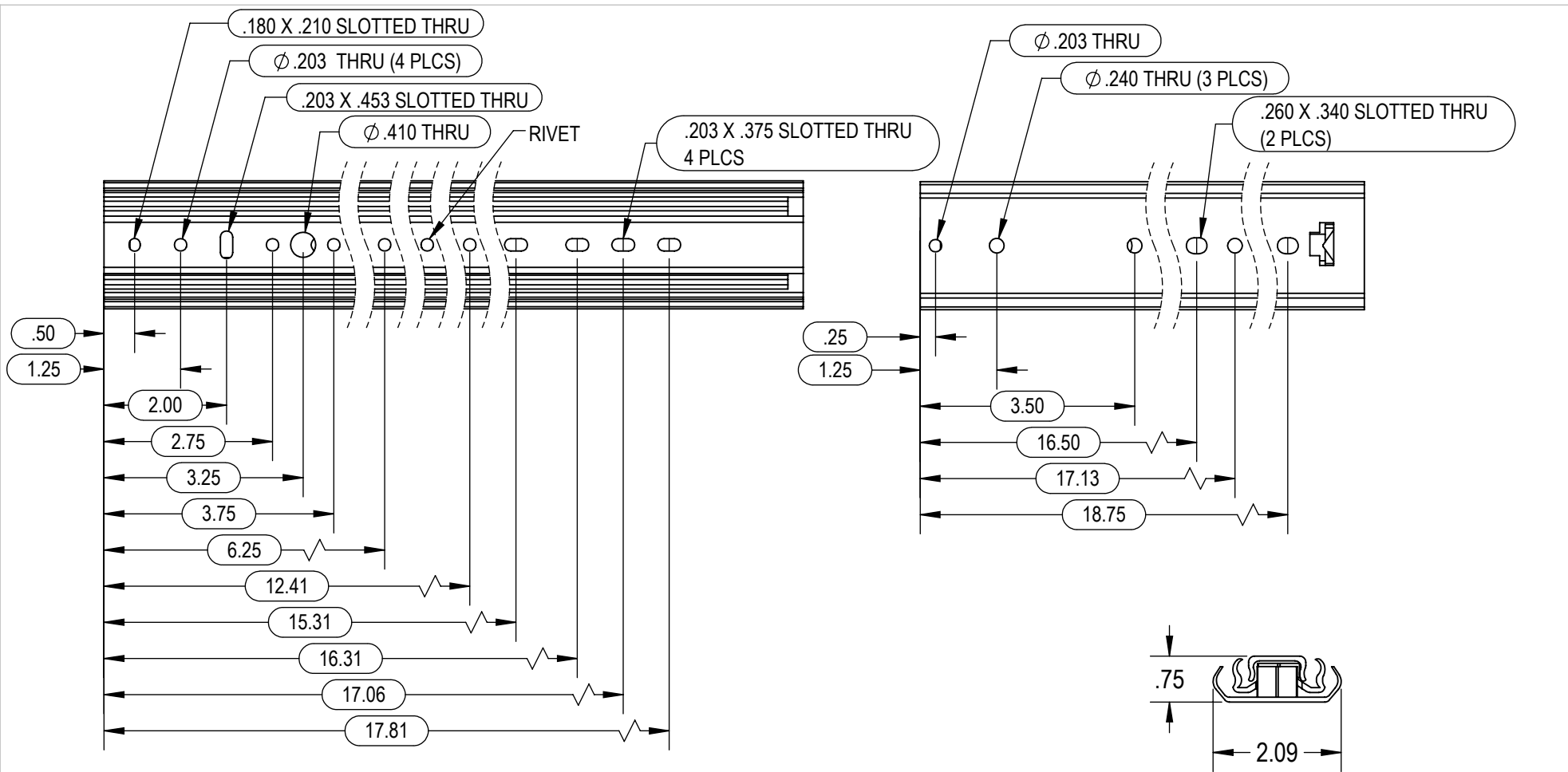

RECOMMENDED
 INNER SLIDE MEMBER:
 #10 MACHINE OR WOOD PAN HEAD SCREW FOR ALL THRU HOLES AND SLOTTED THRU HOLES

OUTER SLIDE MEMBER:
 1/4 HEX BOLT, #14 PAN HEAD WOOD SCREW FOR ALL THRU HOLES AND SLOTTED THRU HOLES

- NOTES:**
- DO NOT SCALE DRAWING.
 - REMOVE ALL BURRS, NO SHARP EDGES.
 - MUST NOT HAVE SCRATCHES, DINGS, OR DENTS.
 - PART TO BE FREE FROM SURFACE IMPERFECTIONS OTHER THAN SURFACE FINISH REQUIREMENTS.
 - CRITICAL DIMENSIONS ARE INDICATED BY:
 - ALL ITEMS ARE TO BE INSPECTED TO 2.5 AQL SAMPLING PLAN UNLESS OTHERWISE STATED.
 - ENSURE PACKAGING WILL PROVIDE ADEQUATE PROTECTION DURING TRANSPORT.
 - GEOMETRIC FEATURES NOT DIMENSIONED ARE CONTROLLED BY 3D MODEL.

THE INFORMATION CONTAINED IN THIS DRAWING IS THE SOLE PROPERTY OF RYADON INC. ANY REPRODUCTION IN PART OR AS A WHOLE WITHOUT THE WRITTEN PERMISSION OF RYADON INC. IS PROHIBITED.

REVISIONS			DEPT.	NAME	DATE
REV.	DESCRIPTION	DATE	SALES	FB	3/18/16
A	INITIAL RELEASE	02/26/15	ENG.	KS	3/18/16
			Q.A.	AH	3/18/16

TOLERANCES UNLESS OTHERWISE SPECIFIED: .X = ± .05 .XX = ± .01 .XXX = ± .008 X/X = ± 1/32" ANGLE = ± 1° SURFACE = ± $\sqrt{.125}$		DESCRIPTION: 2250 SERIES 20" SLIDE	RYADON INC.	
MATERIAL:	STEEL	SIZE A	PART No.	I-DS-2250-20-QD
FINISH:	ZINC PLATED	SCALE:	NTS	SHEET 1 OF 1
			DRAWN BY/DATE	KAS 02/26/15

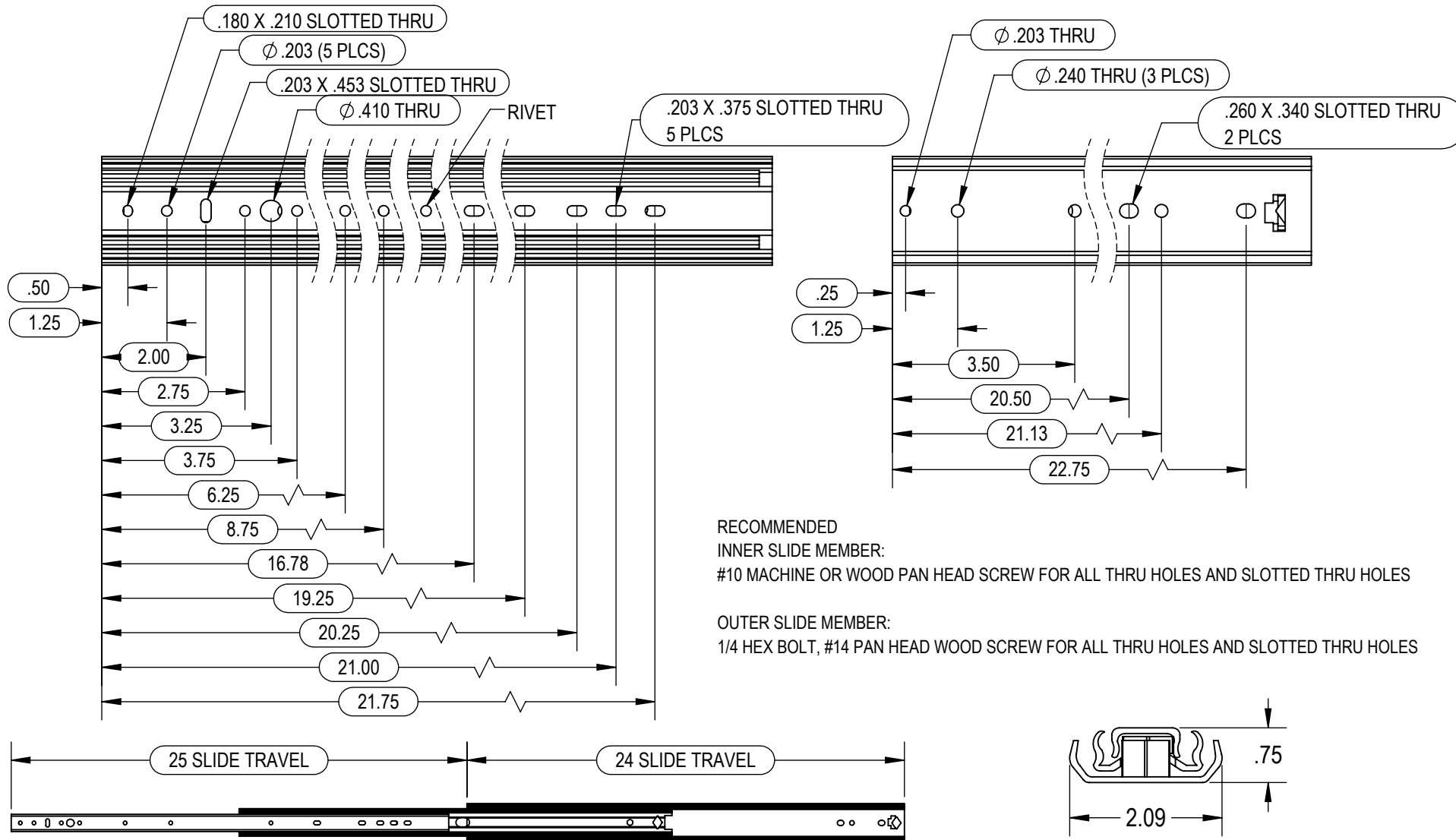

RECOMMENDED
 INNER SLIDE MEMBER:
 #10 MACHINE OR WOOD PAN HEAD SCREW FOR ALL THRU HOLES AND SLOTTED THRU HOLES

OUTER SLIDE MEMBER:
 1/4 HEX BOLT, #14 PAN HEAD WOOD SCREW FOR ALL THRU HOLES AND SLOTTED THRU HOLES

NOTES:

- 1.) DO NOT SCALE DRAWING.
- 2.) REMOVE ALL BURRS, NO SHARP EDGES.
- 3.) MUST NOT HAVE SCRATCHES, DINGS, OR DENTS.
- 4.) PART TO BE FREE FROM SURFACE IMPERFECTIONS OTHER THAN SURFACE FINISH REQUIREMENTS.
- 5.) CRITICAL DIMENSIONS ARE INDICATED BY:
- 6.) ALL ITEMS ARE TO BE INSPECTED TO 2.5 AQL SAMPLING PLAN UNLESS OTHERWISE STATED.
- 7.) ENSURE PACKAGING WILL PROVIDE ADEQUATE PROTECTION DURING TRANSPORT.
- 8.) GEOMETRIC FEATURES NOT DIMENSIONED ARE CONTROLLED BY 3D MODEL.

THE INFORMATION CONTAINED IN THIS DRAWING IS THE SOLE PROPERTY OF RYADON INC. ANY REPRODUCTION IN PART OR AS A WHOLE WITHOUT THE WRITTEN PERMISSION OF RYADON INC. IS PROHIBITED.

REVISIONS			DEPT.	NAME	DATE
REV.	DESCRIPTION	DATE	SALES	FB	3/18/16
A	INITIAL RELEASE	02/26/15	ENG.	KS	3/18/16
			Q.A.	AH	3/18/16
TOLERANCES UNLESS OTHERWISE SPECIFIED: .X = ± .05 .XX = ± .01 .XXX = ± .008 X/X = ± 1/32" ANGLE = ± 1° SURFACE = ± .125/√			DESCRIPTION: 2250 SERIES 24" SLIDE		
MATERIAL: STEEL			RYADON INC.		
FINISH: ZINC PLATED			SIZE A	PART No. I-DS-2250-24-QD	REV A
SCALE: NTS			SHEET 1 OF 1		DRAWN BY/DATE KAS 02/26/15

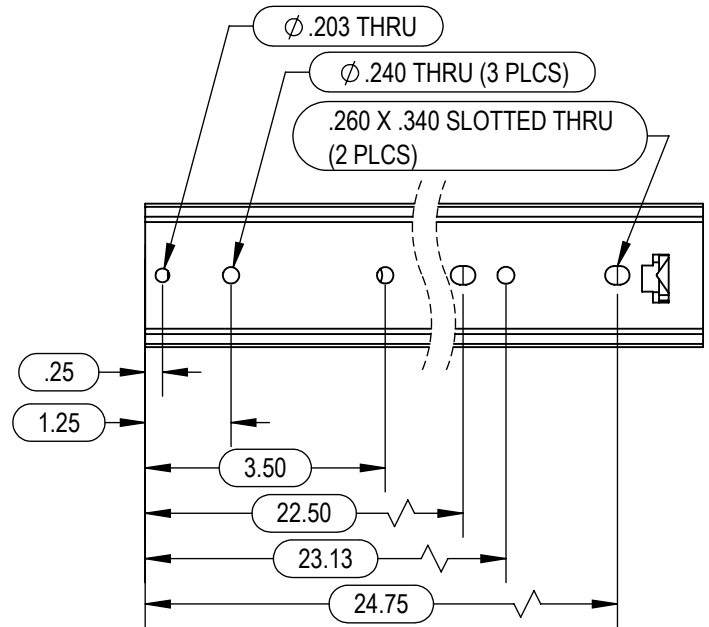
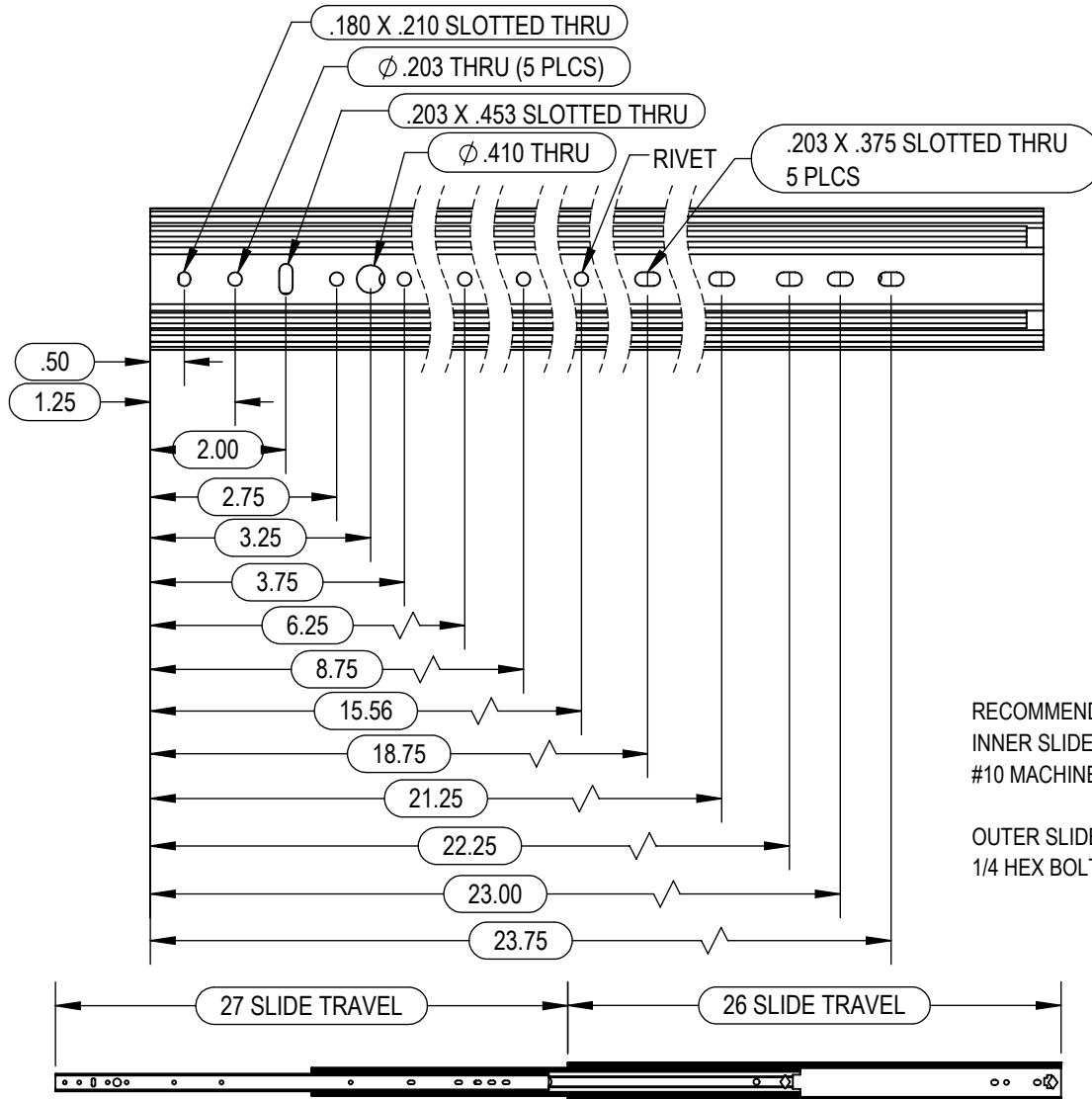

RECOMMENDED
INNER SLIDE MEMBER:
#10 MACHINE OR WOOD PAN HEAD SCREW FOR ALL THRU HOLES AND SLOTTED THRU HOLES

OUTER SLIDE MEMBER:
1/4 HEX BOLT, #14 PAN HEAD WOOD SCREW FOR ALL THRU HOLES AND SLOTTED THRU HOLES

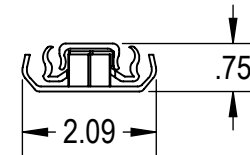

NOTES:

- 1.) DO NOT SCALE DRAWING.
- 2.) REMOVE ALL BURRS, NO SHARP EDGES.
- 3.) MUST NOT HAVE SCRATCHES, DINGS, OR DENTS.
- 4.) PART TO BE FREE FROM SURFACE IMPERFECTIONS OTHER THAN SURFACE FINISH REQUIREMENTS.
- 5.) CRITICAL DIMENSIONS ARE INDICATED BY:
- 6.) ALL ITEMS ARE TO BE INSPECTED TO 2.5 AQL SAMPLING PLAN UNLESS OTHERWISE STATED.
- 7.) ENSURE PACKAGING WILL PROVIDE ADEQUATE PROTECTION DURING TRANSPORT.
- 8.) GEOMETRIC FEATURES NOT DIMENSIONED ARE CONTROLLED BY 3D MODEL.

THE INFORMATION CONTAINED IN THIS DRAWING IS THE SOLE PROPERTY OF RYADON INC. ANY REPRODUCTION IN PART OR AS A WHOLE WITHOUT THE WRITTEN PERMISSION OF RYADON INC. IS PROHIBITED.

REVISIONS			DEPT.	NAME	DATE
REV.	DESCRIPTION	DATE	SALES	FB	3/18/16
A	INITIAL RELEASE	02/26/15	ENG.	KS	3/18/16
			Q.A.	AH	3/18/16
TOLERANCES UNLESS OTHERWISE SPECIFIED: .X = ± .05 .XX = ± .01 .XXX = ± .008 X/X = ± 1/32" ANGLE = ± 1° SURFACE = ± $\sqrt{.125}$			RYADON INC.		
DESCRIPTION: 2250 SERIES 26" SLIDE			SIZE A	PART No. I-DS-2250-26-QD	REV A
MATERIAL: STEEL			SCALE: NTS		
FINISH: ZINC PLATED			SHEET 1 OF 1		
			DRAWN BY/DATE KAS 02/26/15		

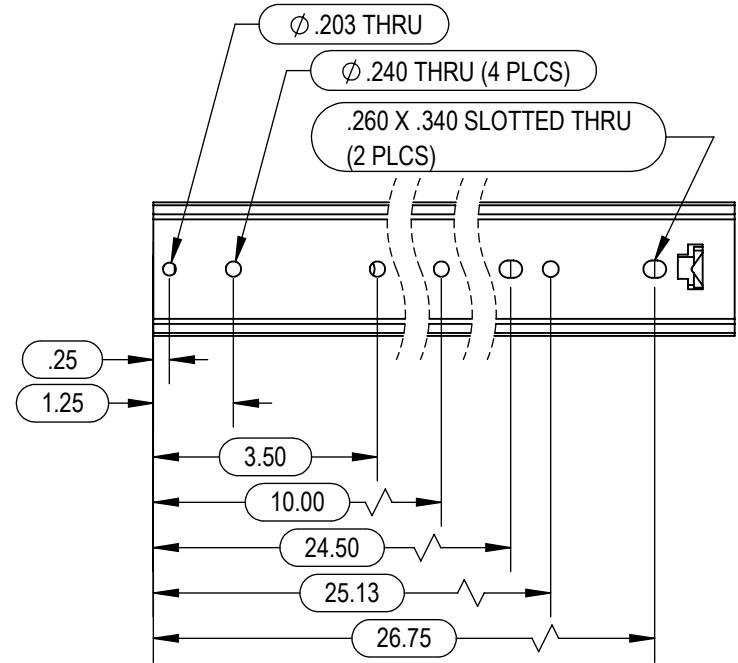
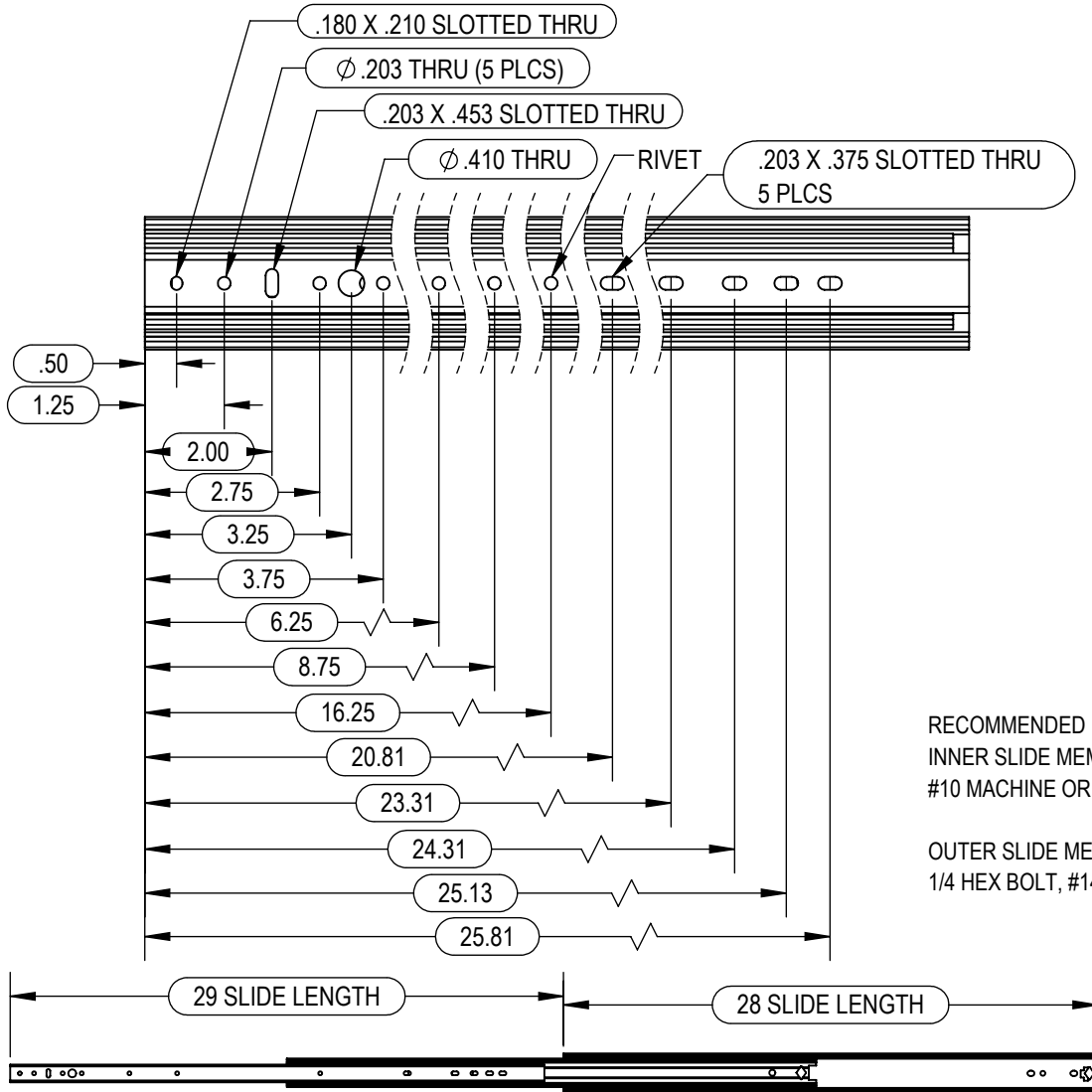

RECOMMENDED
INNER SLIDE MEMBER:

#10 MACHINE OR WOOD PAN HEAD SCREW FOR ALL THRU HOLES AND SLOTTED THRU HOLES

OUTER SLIDE MEMBER:

1/4 HEX BOLT, #14 PAN HEAD WOOD SCREW FOR ALL THRU HOLES AND SLOTTED THRU HOLES

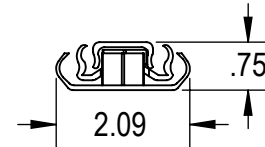

NOTES:

- 1.) DO NOT SCALE DRAWING.
- 2.) REMOVE ALL BURRS, NO SHARP EDGES.
- 3.) MUST NOT HAVE SCRATCHES, DINGS, OR DENTS.
- 4.) PART TO BE FREE FROM SURFACE IMPERFECTIONS OTHER THAN SURFACE FINISH REQUIREMENTS.
- 5.) CRITICAL DIMENSIONS ARE INDICATED BY:
- 6.) ALL ITEMS ARE TO BE INSPECTED TO 2.5 AQL SAMPLING PLAN UNLESS OTHERWISE STATED.
- 7.) ENSURE PACKAGING WILL PROVIDE ADEQUATE PROTECTION DURING TRANSPORT.
- 8.) GEOMETRIC FEATURES NOT DIMENSIONED ARE CONTROLLED BY 3D MODEL.

THE INFORMATION CONTAINED IN THIS DRAWING IS THE SOLE PROPERTY OF RYADON INC. ANY REPRODUCTION IN PART OR AS A WHOLE WITHOUT THE WRITTEN PERMISSION OF RYADON INC. IS PROHIBITED.

REVISIONS			DEPT.	NAME	DATE
REV.	DESCRIPTION	DATE	SALES	FB	3/18/16
A	INITIAL RELEASE	03/02/15	ENG.	KS	3/18/16
			Q.A.	AH	3/18/16
TOLERANCES UNLESS OTHERWISE SPECIFIED: .X = ± .05 .XX = ± .01 .XXX = ± .008 X/X = ± 1/32" ANGLE = ± 1° SURFACE = ± .125/√			DESCRIPTION: 2250 SERIES 28" SLIDE		
			MATERIAL: STEEL		
FINISH: ZINC PLATED			SCALE: NTS SHEET 1 OF 1		
			RYADON INC.		
			REV A DRAWN BY/DATE KAS 03/02/15		

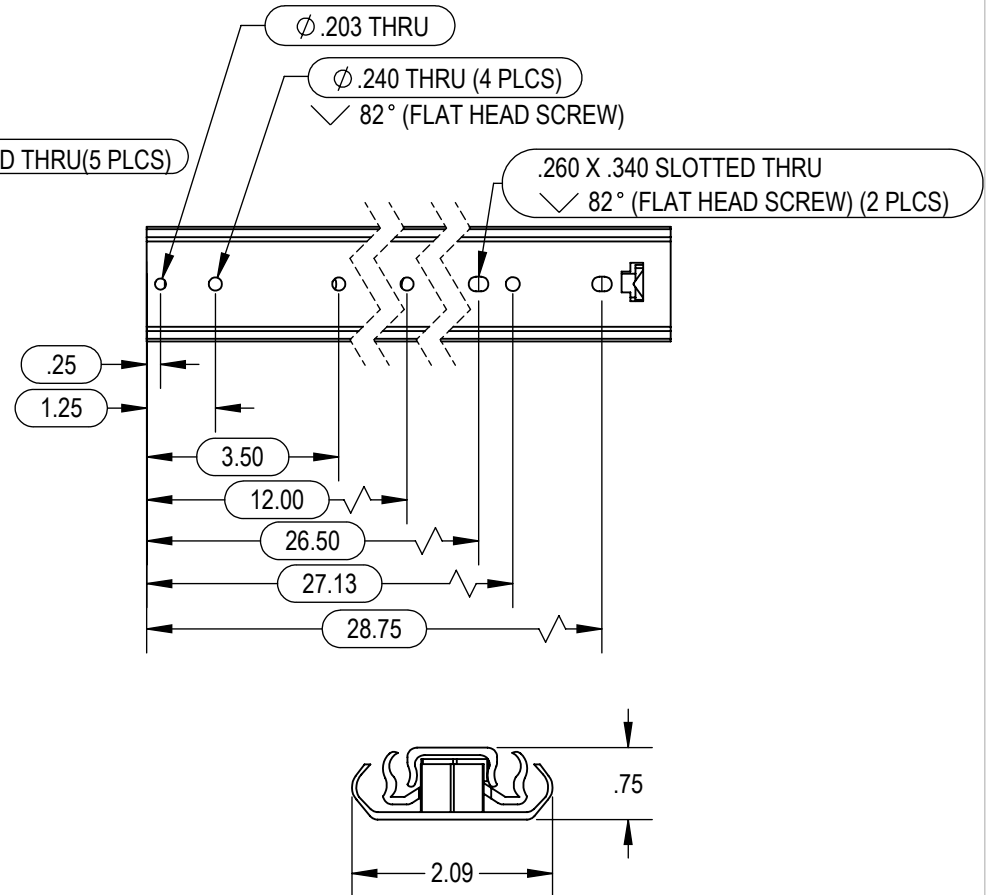
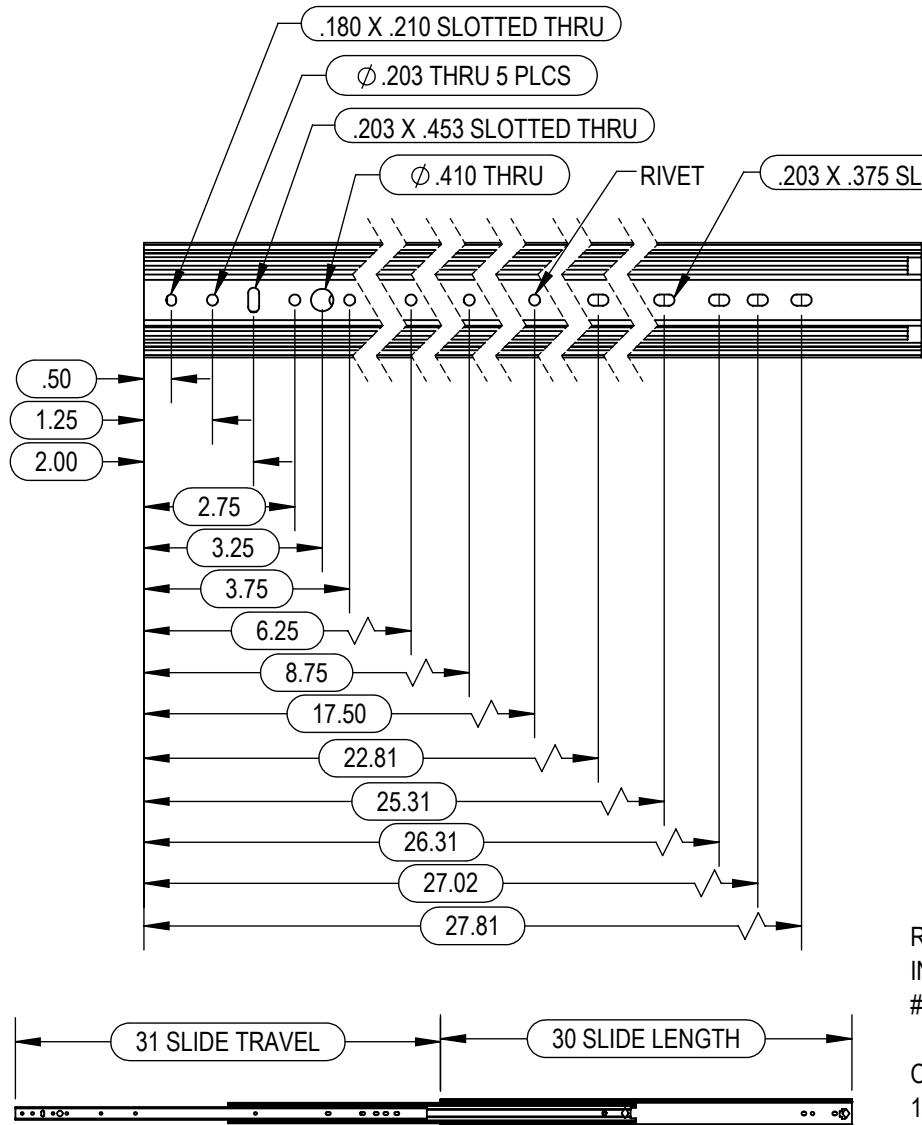

RECOMMENDED

INNER SLIDE MEMBER:

#10 MACHINE OR WOOD PAN HEAD SCREW FOR ALL THRU HOLES AND SLOTTED THRU HOLES

OUTER SLIDE MEMBER:

1/4 HEX BOLT, #14 PAN HEAD WOOD SCREW FOR ALL THRU HOLES AND SLOTTED THRU HOLES

NOTES:

- DO NOT SCALE DRAWING.
- REMOVE ALL BURRS, NO SHARP EDGES.
- MUST NOT HAVE SCRATCHES, DINGS, OR DENTS.
- PART TO BE FREE FROM SURFACE IMPERFECTIONS OTHER THAN SURFACE FINISH REQUIREMENTS.
- CRITICAL DIMENSIONS ARE INDICATED BY:
- ALL ITEMS ARE TO BE INSPECTED TO 2.5 AQL SAMPLING PLAN UNLESS OTHERWISE STATED.
- ENSURE PACKAGING WILL PROVIDE ADEQUATE PROTECTION DURING TRANSPORT.
- GEOMETRIC FEATURES NOT DIMENSIONED ARE CONTROLLED BY 3D MODEL.

THE INFORMATION CONTAINED IN THIS DRAWING IS THE SOLE PROPERTY OF RYADON INC. ANY REPRODUCTION IN PART OR AS A WHOLE WITHOUT THE WRITTEN PERMISSION OF RYADON INC. IS PROHIBITED.

REVISIONS			DEPT.	NAME	DATE
REV.	DESCRIPTION	DATE	SALES	FB	3/18/16
A	INITIAL RELEASE	03/02/15	ENG.	KS	3/18/16
			Q.A.	AH	3/18/16
TOLERANCES UNLESS OTHERWISE SPECIFIED: .X = ± .05 .XX = ± .01 .XXX = ± .008 X/X = ± 1/32" ANGLE = ± 1° SURFACE = ± √.125			DESCRIPTION: 2250 SERIES 30" SLIDE		
MATERIAL: STEEL			RYADON INC.		
FINISH: ZINC PLATED			SIZE A PART No. I-DS-2250-30-QD		
SCALE: NTS			SHEET 1 OF 1		
DRAWN BY/DATE KAS 03/02/15			REV A		



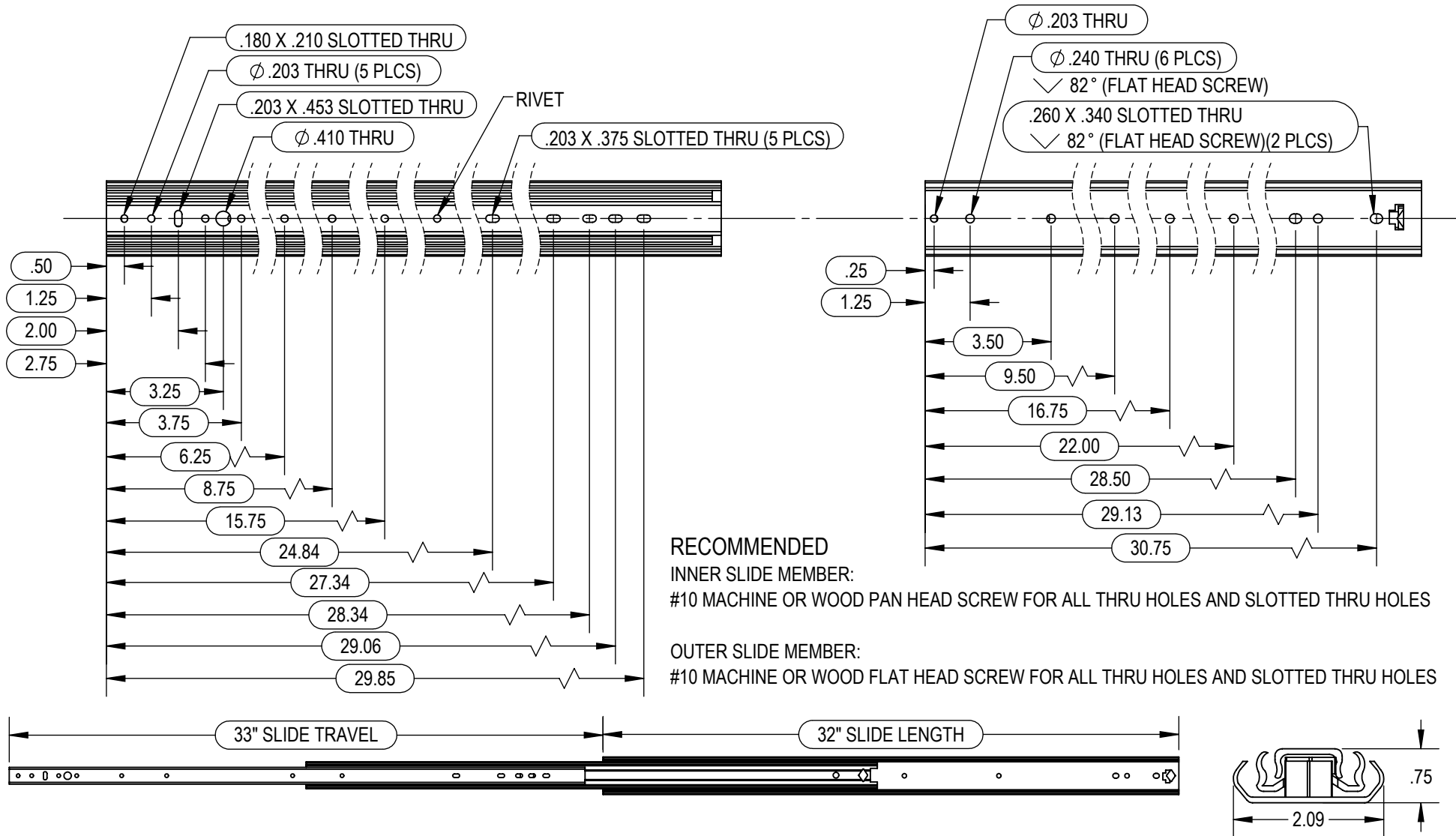

RECOMMENDED
 INNER SLIDE MEMBER:
 #10 MACHINE OR WOOD PAN HEAD SCREW FOR ALL THRU HOLES AND SLOTTED THRU HOLES

OUTER SLIDE MEMBER:
 #10 MACHINE OR WOOD FLAT HEAD SCREW FOR ALL THRU HOLES AND SLOTTED THRU HOLES

NOTES:

- 1.) DO NOT SCALE DRAWING.
- 2.) REMOVE ALL BURRS, NO SHARP EDGES.
- 3.) MUST NOT HAVE SCRATCHES, DINGS, OR DENTS.
- 4.) PART TO BE FREE FROM SURFACE IMPERFECTIONS OTHER THAN SURFACE FINISH REQUIREMENTS.
- 5.) CRITICAL DIMENSIONS ARE INDICATED BY:
- 6.) ALL ITEMS ARE TO BE INSPECTED TO 2.5 AQL SAMPLING PLAN UNLESS OTHERWISE STATED.
- 7.) ENSURE PACKAGING WILL PROVIDE ADEQUATE PROTECTION DURING TRANSPORT.
- 8.) GEOMETRIC FEATURES NOT DIMENSIONED ARE CONTROLLED BY 3D MODEL.

THE INFORMATION CONTAINED IN THIS DRAWING IS THE SOLE PROPERTY OF RYADON INC. ANY REPRODUCTION IN PART OR AS A WHOLE WITHOUT THE WRITTEN PERMISSION OF RYADON INC. IS PROHIBITED.

REVISIONS			DEPT.	NAME	DATE
REV.	DESCRIPTION	DATE	SALES	FB	3/18/16
A	INITIAL RELEASE	03/02/15	ENG.	KS	3/18/16
			Q.A.	AH	3/18/16
TOLERANCES UNLESS OTHERWISE SPECIFIED: .X = ± .05 .XX = ± .01 .XXX = ± .008 X/X = ± 1/32" ANGLE = ± 1° SURFACE = ± $\sqrt{.125}$			RYADON INC.		
DESCRIPTION: 2250 SERIES 32" SLIDE			SIZE A	PART No. I-DS-2250-32-QD	REV A
MATERIAL: STEEL			SCALE: NTS		
FINISH: ZINC PLATED			SHEET 1 OF 1		
			DRAWN BY/DATE KAS 03/02/15		

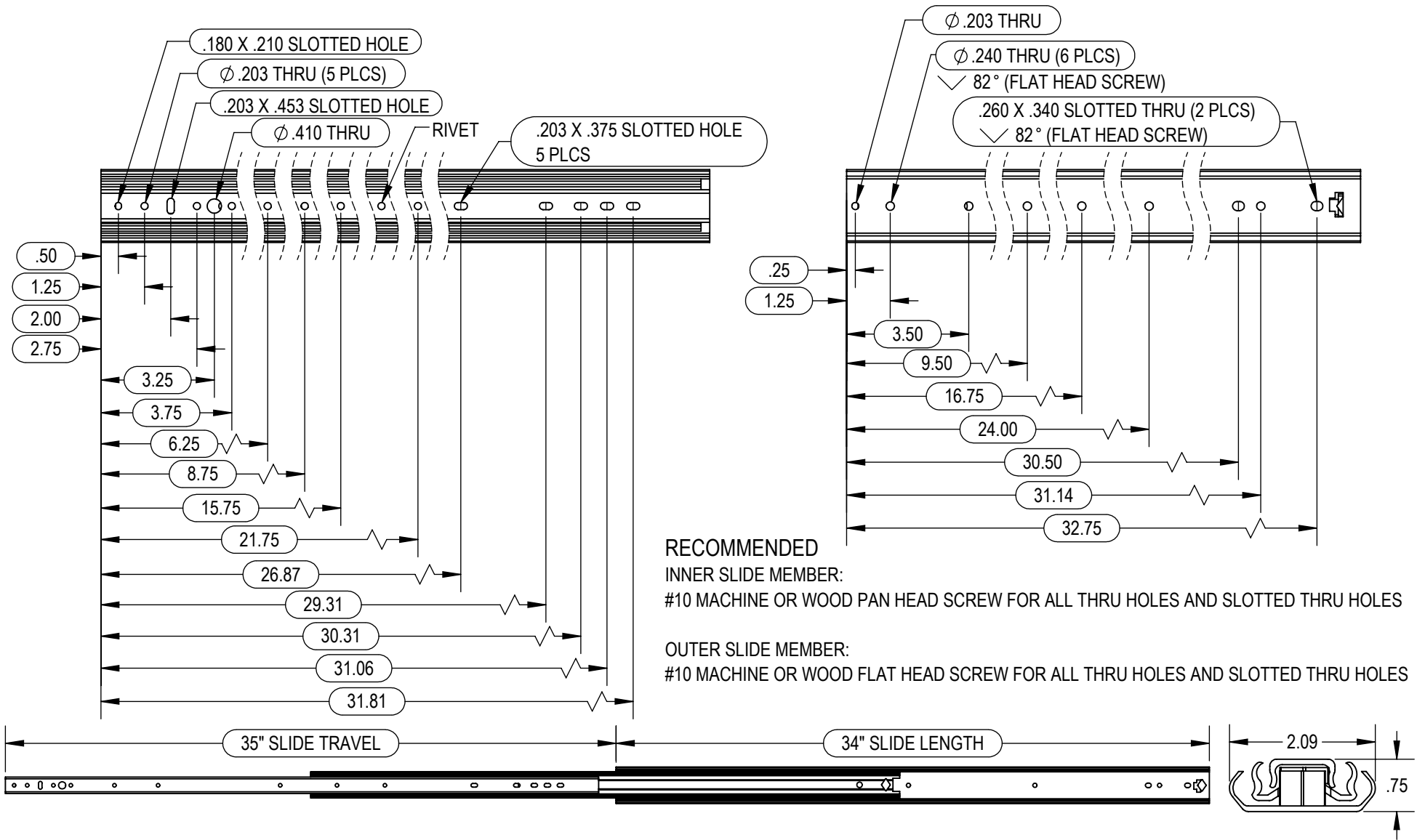

RECOMMENDED
 INNER SLIDE MEMBER:
 #10 MACHINE OR WOOD PAN HEAD SCREW FOR ALL THRU HOLES AND SLOTTED THRU HOLES

OUTER SLIDE MEMBER:
 #10 MACHINE OR WOOD FLAT HEAD SCREW FOR ALL THRU HOLES AND SLOTTED THRU HOLES

NOTES:

- 1.) DO NOT SCALE DRAWING.
- 2.) REMOVE ALL BURRS, NO SHARP EDGES.
- 3.) MUST NOT HAVE SCRATCHES, DINGS, OR DENTS.
- 4.) PART TO BE FREE FROM SURFACE IMPERFECTIONS OTHER THAN SURFACE FINISH REQUIREMENTS.
- 5.) CRITICAL DIMENSIONS ARE INDICATED BY:
- 6.) ALL ITEMS ARE TO BE INSPECTED TO 2.5 AQL SAMPLING PLAN UNLESS OTHERWISE STATED.
- 7.) ENSURE PACKAGING WILL PROVIDE ADEQUATE PROTECTION DURING TRANSPORT.
- 8.) GEOMETRIC FEATURES NOT DIMENSIONED ARE CONTROLLED BY 3D MODEL.

THE INFORMATION CONTAINED IN THIS DRAWING IS THE SOLE PROPERTY OF RYADON INC. ANY REPRODUCTION IN PART OR AS A WHOLE WITHOUT THE WRITTEN PERMISSION OF RYADON INC. IS PROHIBITED.

REVISIONS			DEPT.	NAME	DATE
REV.	DESCRIPTION	DATE	SALES	FB	3/18/16
A	INITIAL RELEASE	03/02/15	ENG.	KS	3/18/16
			Q.A.	AH	3/18/16

TOLERANCES UNLESS OTHERWISE SPECIFIED: .X = ± .05 .XX = ± .01 .XXX = ± .008 X/X = ± 1/32" ANGLE = ± 1° SURFACE = ± $\sqrt{.125}$		DESCRIPTION: 2250 SERIES 34" SLIDE	RYADON INC.		SIZE A PART No. I-DS-2250-34-QD REV A
MATERIAL: STEEL FINISH: ZINC PLATED		SCALE: NTS SHEET 1 OF 1			

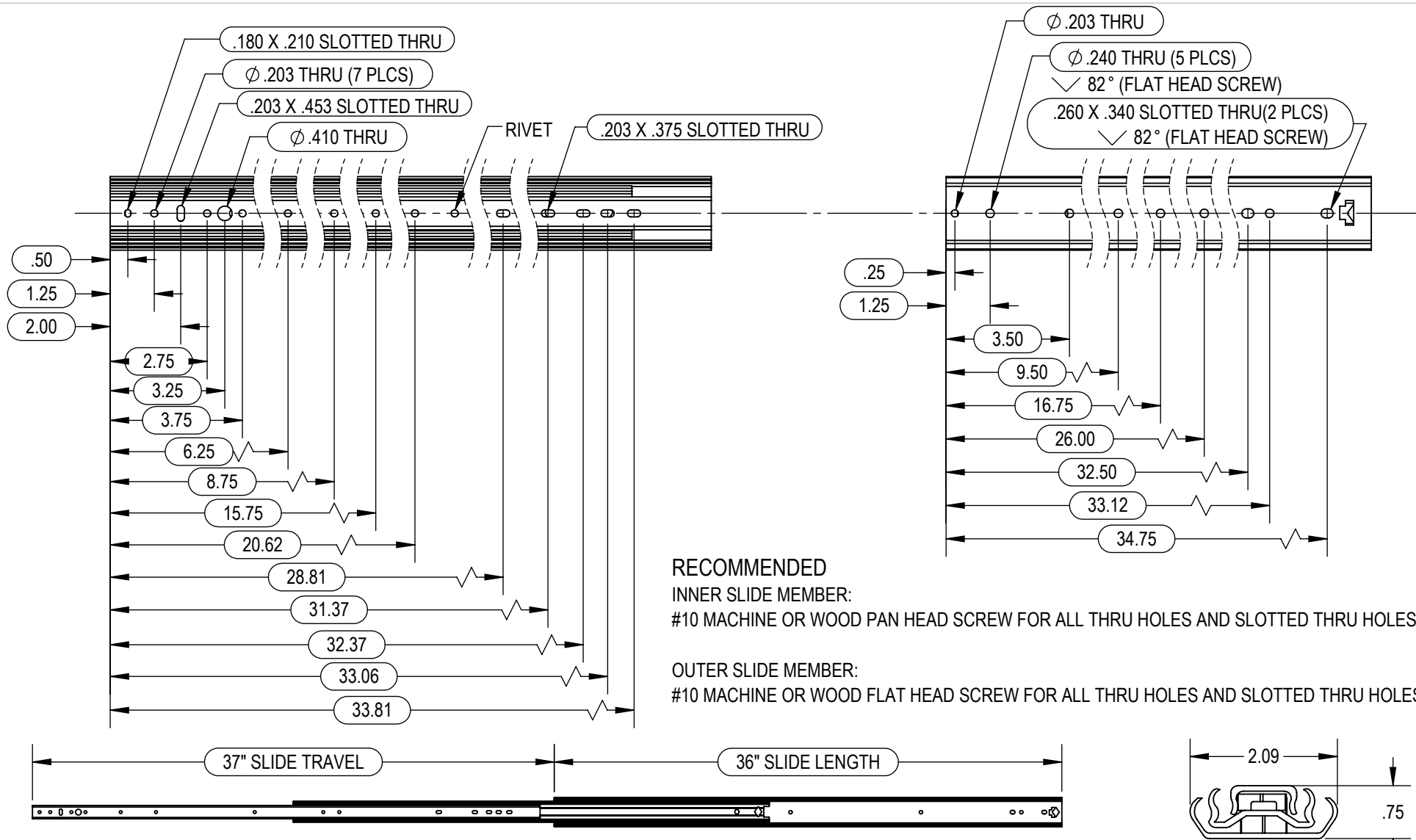

RECOMMENDED
 INNER SLIDE MEMBER:
 #10 MACHINE OR WOOD PAN HEAD SCREW FOR ALL THRU HOLES AND SLOTTED THRU HOLES

OUTER SLIDE MEMBER:
 #10 MACHINE OR WOOD FLAT HEAD SCREW FOR ALL THRU HOLES AND SLOTTED THRU HOLES

- NOTES:**
- 1.) DO NOT SCALE DRAWING.
 - 2.) REMOVE ALL BURRS, NO SHARP EDGES.
 - 3.) MUST NOT HAVE SCRATCHES, DINGS, OR DENTS.
 - 4.) PART TO BE FREE FROM SURFACE IMPERFECTIONS OTHER THAN SURFACE FINISH REQUIREMENTS.
 - 5.) CRITICAL DIMENSIONS ARE INDICATED BY:
 - 6.) ALL ITEMS ARE TO BE INSPECTED TO 2.5 AQL SAMPLING PLAN UNLESS OTHERWISE STATED.
 - 7.) ENSURE PACKAGING WILL PROVIDE ADEQUATE PROTECTION DURING TRANSPORT.
 - 8.) GEOMETRIC FEATURES NOT DIMENSIONED ARE CONTROLLED BY 3D MODEL.

THE INFORMATION CONTAINED IN THIS DRAWING IS THE SOLE PROPERTY OF RYADON INC. ANY REPRODUCTION IN PART OR AS A WHOLE WITHOUT THE WRITTEN PERMISSION OF RYADON INC. IS PROHIBITED.

REVISIONS			DEPT.	NAME	DATE
REV.	DESCRIPTION	DATE	SALES	FB	3/18/16
A	INITIAL RELEASE	03/02/15	ENG.	KS	3/18/16
			Q.A.	AH	3/18/16
TOLERANCES UNLESS OTHERWISE SPECIFIED: .X = ± .05 .XX = ± .01 .XXX = ± .008 X/X = ± 1/32" ANGLE = ± 1° SURFACE = ± .125/√			RYADON INC.		
DESCRIPTION: 2250 SERIES 36" SLIDE			SIZE A	PART No. I-DS-2250-36-QD	REV A
MATERIAL: STEEL			SCALE: NTS SHEET 1 OF 1		
FINISH: ZINC PLATED			DRAWN BY/DATE KAS 03/02/15		