

HOOKED SHAPED TAB TO STOP RELEASE LEVER

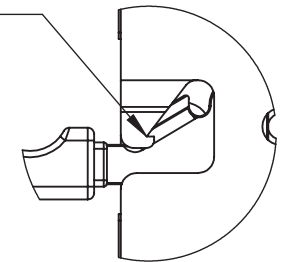

DETAIL A  
SCALE 2 : 3

LEFT HAND VERSION

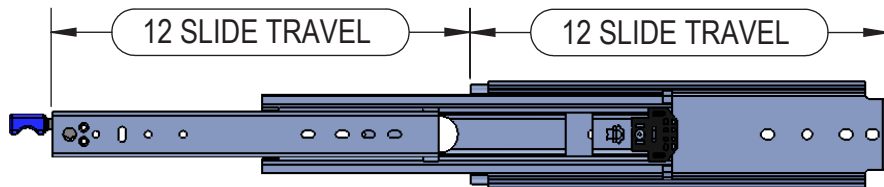

RECOMMENDED

INNER SLIDE MEMBER:

#10 MACHINE OR WOOD PAN HEAD SCREW FOR ALL THRU HOLES AND SLOTTED THRU HOLES

OUTER SLIDE MEMBER:

1/4 HEX BOLT, #14 PAN HEAD WOOD SCREW FOR ALL THRU HOLES AND SLOTTED THRU HOLES

**NOTES:**

- 1.) DO NOT SCALE DRAWING.
- 2.) REMOVE ALL BURRS, NO SHARP EDGES.
- 3.) MUST NOT HAVE SCRATCHES, DINGS, OR DENTS.
- 4.) PART TO BE FREE FROM SURFACE IMPERFECTIONS OTHER THAN SURFACE FINISH REQUIREMENTS.
- 5.) CRITICAL DIMENSIONS ARE INDICATED BY:
- 6.) ALL ITEMS ARE TO BE INSPECTED TO 2.5 AQL SAMPLING PLAN UNLESS OTHERWISE STATED.
- 7.) ENSURE PACKAGING WILL PROVIDE ADEQUATE PROTECTION DURING TRANSPORT.
- 8.) GEOMETRIC FEATURES NOT DIMENSIONED ARE CONTROLLED BY 3D MODEL.

THE INFORMATION CONTAINED IN THIS DRAWING IS THE SOLE PROPERTY OF RYADON INC. ANY REPRODUCTION IN PART OR AS A WHOLE WITHOUT THE WRITTEN PERMISSION OF RYADON INC. IS PROHIBITED.

REVISIONS			DEPT.	NAME	DATE
REV.	DESCRIPTION	DATE	SALES	ENG.	
A	INITIAL RELEASE	03/11/15	Q.A.		
TOLERANCES UNLESS OTHERWISE SPECIFIED: .X = ± .05 .XX = ± .03 .XXX = ± .015 X/X = ± 1/32" ANGLE = ± 1° SURFACE = ± .125/√			DESCRIPTION: <b>12" 3600 SERIES SLIDE</b> MATERIAL: STEEL FINISH: ZINC PLATED		
RYADON INC.			SIZE A	PART No. I-DS-3600-12	REV A
SCALE: NTS			SHEET 1 OF 1		DRAWN BY/DATE KAS 3/11/15

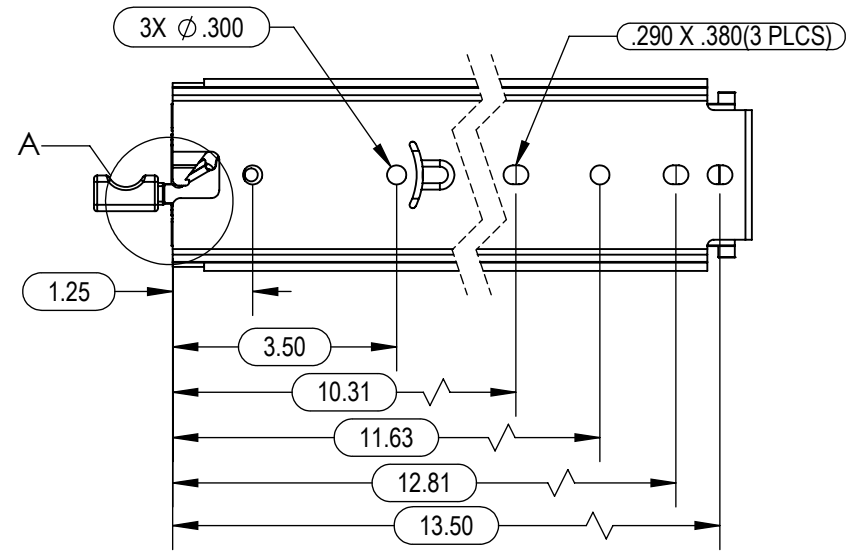
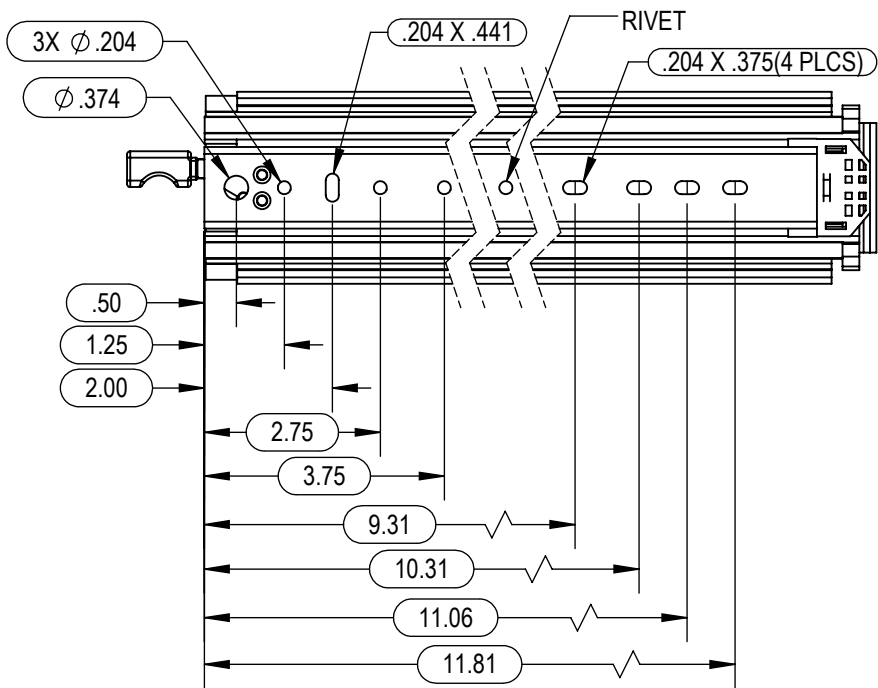

HOOKED SHAPED TAB TO STOP RELEASE LEVER

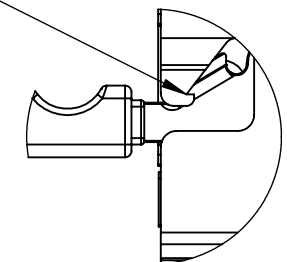
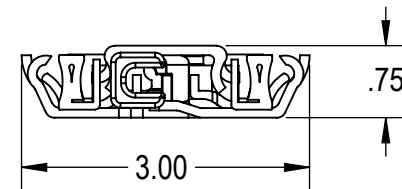

DETAIL A  
SCALE 2 : 3

LEFT HAND VERSION

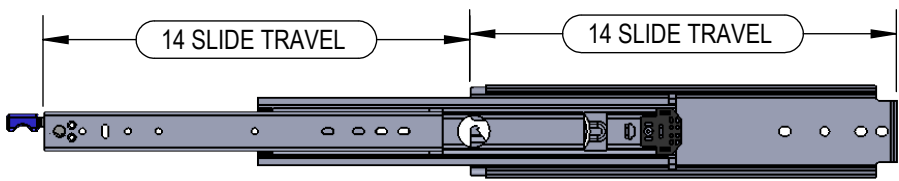

RECOMMENDED  
INNER SLIDE MEMBER:  
#10 MACHINE OR WOOD PAN HEAD SCREW FOR ALL THRU HOLES AND SLOTTED THRU HOLES

OUTER SLIDE MEMBER:  
1/4 HEX BOLT, #14 PAN HEAD WOOD SCREW FOR ALL THRU HOLES AND SLOTTED THRU HOLES

**NOTES:**

- 1.) DO NOT SCALE DRAWING.
- 2.) REMOVE ALL BURRS, NO SHARP EDGES.
- 3.) MUST NOT HAVE SCRATCHES, DINGS, OR DENTS.
- 4.) PART TO BE FREE FROM SURFACE IMPERFECTIONS OTHER THAN SURFACE FINISH REQUIREMENTS.
- 5.) CRITICAL DIMENSIONS ARE INDICATED BY:
- 6.) ALL ITEMS ARE TO BE INSPECTED TO 2.5 AQL SAMPLING PLAN UNLESS OTHERWISE STATED.
- 7.) ENSURE PACKAGING WILL PROVIDE ADEQUATE PROTECTION DURING TRANSPORT.
- 8.) GEOMETRIC FEATURES NOT DIMENSIONED ARE CONTROLLED BY 3D MODEL.

THE INFORMATION CONTAINED IN THIS DRAWING IS THE SOLE PROPERTY OF RYADON INC. ANY REPRODUCTION IN PART OR AS A WHOLE WITHOUT THE WRITTEN PERMISSION OF RYADON INC. IS PROHIBITED.

REVISIONS			DEPT.	NAME	DATE
REV.	DESCRIPTION	DATE	SALES		
A	INITIAL RELEASE	03/11/15	ENG.		
			Q.A.		
TOLERANCES UNLESS OTHERWISE SPECIFIED: .X = ± .05 .XX = ± .03 .XXX = ± .015 X/X = ± 1/32" ANGLE = ± 1° SURFACE = ± <sup>.125</sup> √			DESCRIPTION: <b>14" 3600 SERIES SLIDE</b> MATERIAL: STEEL FINISH: ZINC PLATED		
SIZE A PART No. I-DS-3600-14			<b>RYADON INC.</b> 		
SCALE: NTS			SHEET 1 OF 1		REV A DRAWN BY/DATE KAS 3/11/15

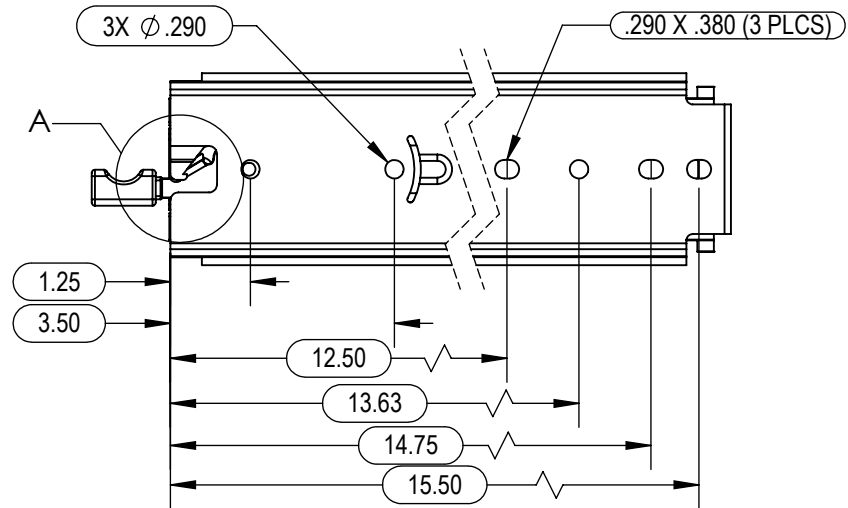
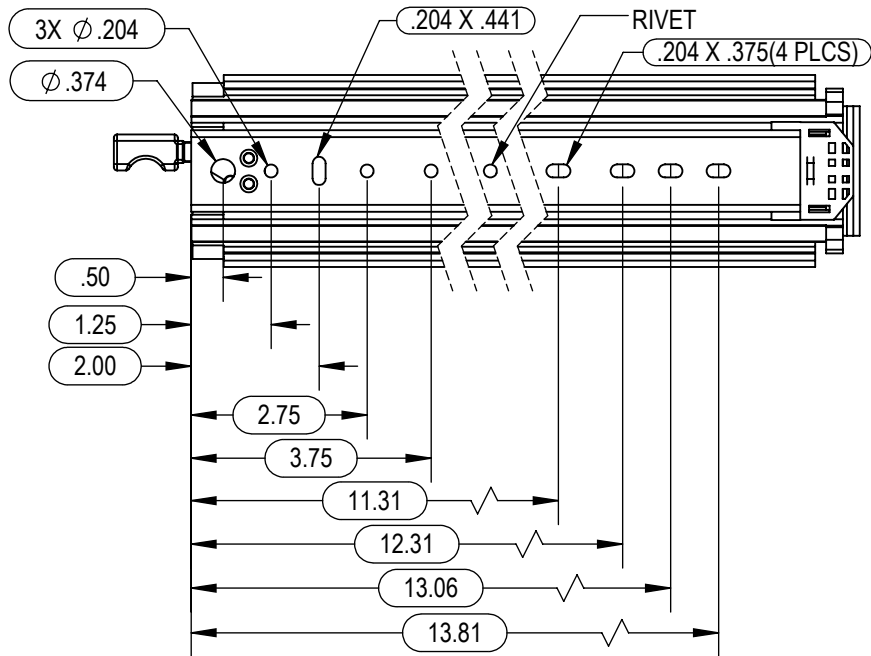

HOOKED SHAPED TAB TO STOP RELEASE LEVER

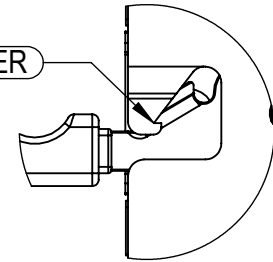

DETAIL A  
SCALE 2 : 3

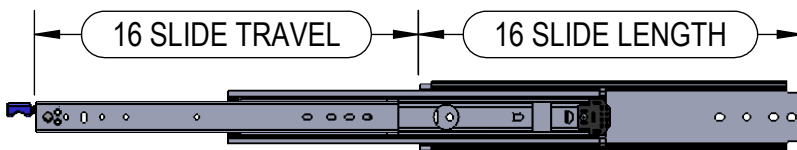
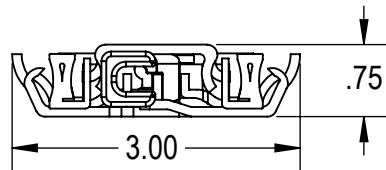

LEFT HAND VERSION

RECOMMENDED

INNER SLIDE MEMBER:

#10 MACHINE OR WOOD PAN HEAD SCREW FOR ALL THRU HOLES AND SLOTTED THRU HOLES

OUTER SLIDE MEMBER:

1/4 HEX BOLT, #14 PAN HEAD WOOD SCREW FOR ALL THRU HOLES AND SLOTTED THRU HOLES

NOTES:

- 1.) DO NOT SCALE DRAWING.
- 2.) REMOVE ALL BURRS, NO SHARP EDGES.
- 3.) MUST NOT HAVE SCRATCHES, DINGS, OR DENTS.
- 4.) PART TO BE FREE FROM SURFACE IMPERFECTIONS OTHER THAN SURFACE FINISH REQUIREMENTS.
- 5.) CRITICAL DIMENSIONS ARE INDICATED BY:
- 6.) ALL ITEMS ARE TO BE INSPECTED TO 2.5 AQL SAMPLING PLAN UNLESS OTHERWISE STATED.
- 7.) ENSURE PACKAGING WILL PROVIDE ADEQUATE PROTECTION DURING TRANSPORT.
- 8.) GEOMETRIC FEATURES NOT DIMENSIONED ARE CONTROLLED BY 3D MODEL.

THE INFORMATION CONTAINED IN THIS DRAWING IS THE SOLE PROPERTY OF RYADON INC. ANY REPRODUCTION IN PART OR AS A WHOLE WITHOUT THE WRITTEN PERMISSION OF RYADON INC. IS PROHIBITED.

REVISIONS			DEPT.	NAME	DATE
REV.	DESCRIPTION	DATE	SALES		
A	INITIAL RELEASE	03/11/15	ENG.		
TOLERANCES UNLESS OTHERWISE SPECIFIED:			Q.A.		
.X = ± .05 .XX = ± .03 .XXX = ± .015 X/X = ± 1/32" ANGLE = ± 1° SURFACE = ± .125/√			DESCRIPTION: <b>16" 3600 SERIES SLIDE</b>		
MATERIAL: <b>STEEL</b>			<b>RYADON INC.</b>		
FINISH: <b>ZINC PLATED</b>			SIZE <b>A</b>	PART No. <b>I-DS-3600-16</b>	
SCALE: NTS			SHEET 1 OF 1		REV <b>A</b>
			DRAWN BY/DATE KAS 3/11/15		



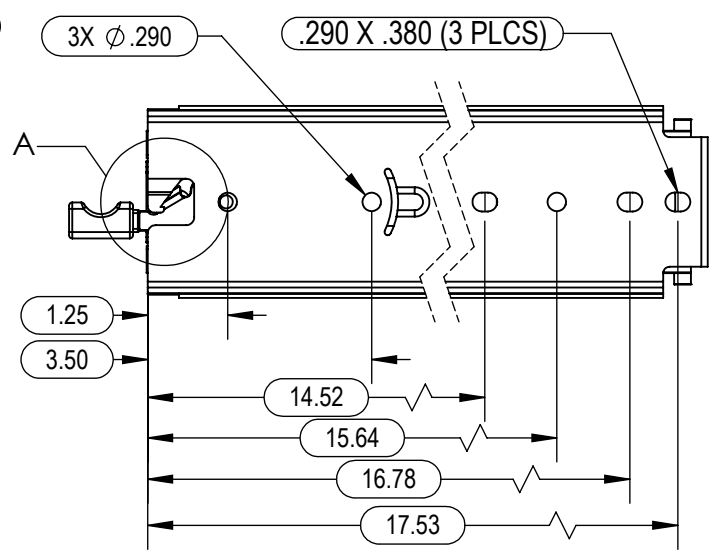
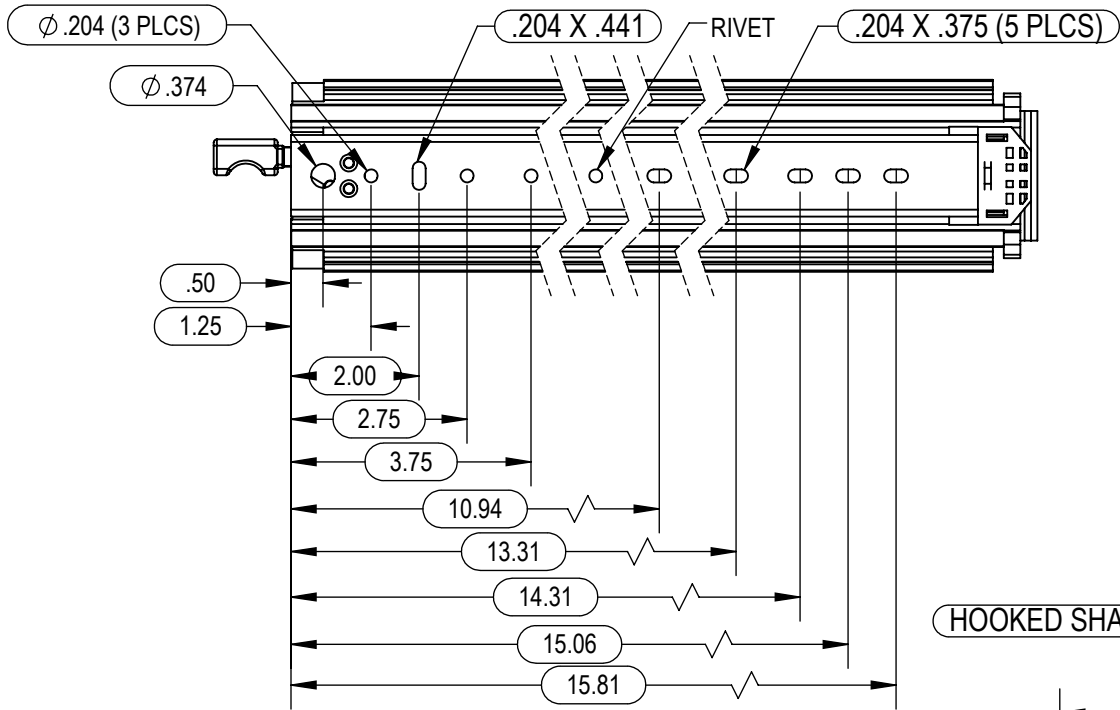

HOOKED SHAPED TAB TO STOP RELEASE LEVER

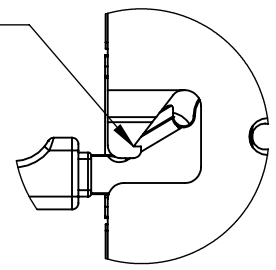
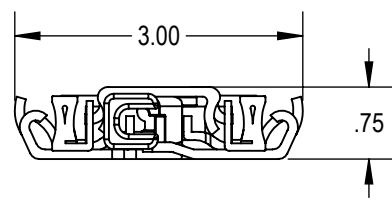

DETAIL A  
SCALE 2 : 3

LEFT HAND VERSION

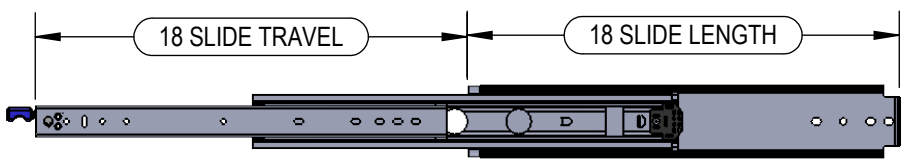

RECOMMENDED

INNER SLIDE MEMBER:

#10 MACHINE OR WOOD PAN HEAD SCREW FOR ALL THRU HOLES AND SLOTTED THRU HOLES

OUTER SLIDE MEMBER:

1/4 HEX BOLT, #14 PAN HEAD WOOD SCREW FOR ALL THRU HOLES AND SLOTTED THRU HOLES

NOTES:

- 1.) DO NOT SCALE DRAWING.
- 2.) REMOVE ALL BURRS, NO SHARP EDGES.
- 3.) MUST NOT HAVE SCRATCHES, DINGS, OR DENTS.
- 4.) PART TO BE FREE FROM SURFACE IMPERFECTIONS OTHER THAN SURFACE FINISH REQUIREMENTS.
- 5.) CRITICAL DIMENSIONS ARE INDICATED BY:
- 6.) ALL ITEMS ARE TO BE INSPECTED TO 2.5 AQL SAMPLING PLAN UNLESS OTHERWISE STATED.
- 7.) ENSURE PACKAGING WILL PROVIDE ADEQUATE PROTECTION DURING TRANSPORT.
- 8.) GEOMETRIC FEATURES NOT DIMENSIONED ARE CONTROLLED BY 3D MODEL.

THE INFORMATION CONTAINED IN THIS DRAWING IS THE SOLE PROPERTY OF RYADON INC. ANY REPRODUCTION IN PART OR AS A WHOLE WITHOUT THE WRITTEN PERMISSION OF RYADON INC. IS PROHIBITED.

REVISIONS			DEPT.	NAME	DATE
REV.	DESCRIPTION	DATE	SALES		
A	INITIAL RELEASE	03/11/15	ENG.		
B	UPDATED PRINT FOR FASTENERS	9/30/2015	Q.A.		

TOLERANCES UNLESS OTHERWISE SPECIFIED:		DESCRIPTION:	
.X = ± .05	.XX = ± .03	18" 3600 SERIES SLIDE	
.XXX = ± .015	X/X = ± 1/32"	MATERIAL:	STEEL
ANGLE = ± 1°	SURFACE = ± .125/√	FINISH:	ZINC PLATED
		SIZE A	PART No. I-DS-3600-18
		SCALE: NTS	SHEET 1 OF 1

**RYADON INC.**

REV B  
DRAWN BY/DATE  
KAS 3/11/15

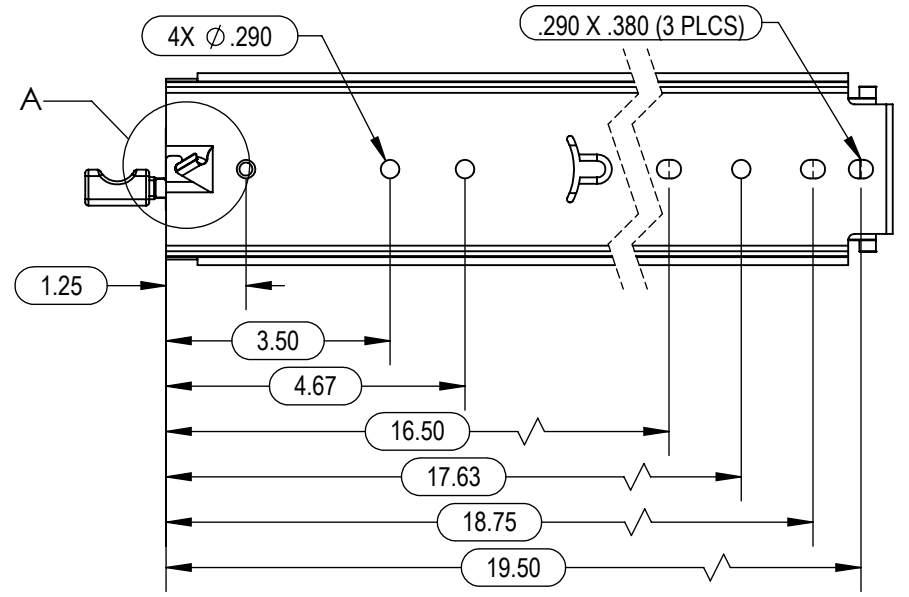
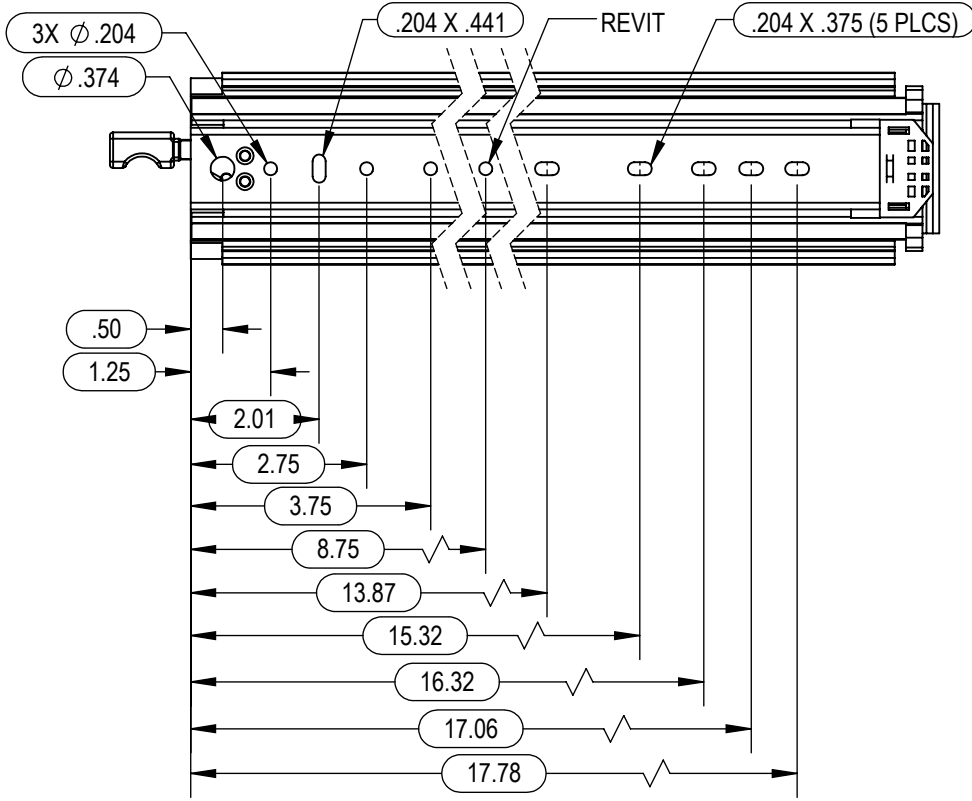

HOOKED SHAPED TAB TO STOP RELEASE LEVER

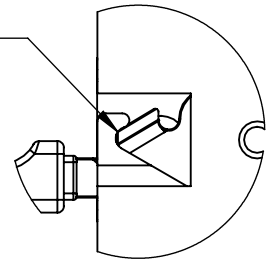
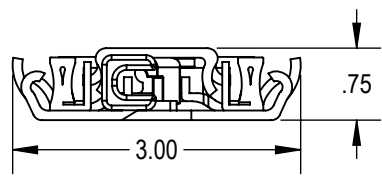

DETAIL A  
SCALE 2 : 3

RECOMMENDED  
INNER SLIDE MEMBER:  
#10 MACHINE OR WOOD PAN HEAD SCREW FOR ALL THRU HOLES AND SLOTTED THRU HOLES

OUTER SLIDE MEMBER:  
1/4 HEX BOLT, #14 PAN HEAD WOOD SCREW FOR ALL THRU HOLES AND SLOTTED THRU HOLES

NOTES:

- 1) DO NOT SCALE DRAWING.
- 2) REMOVE ALL BURRS, NO SHARP EDGES.
- 3) MUST NOT HAVE SCRATCHES, DINGS, OR DENTS.
- 4) PART TO BE FREE FROM SURFACE IMPERFECTIONS OTHER THAN SURFACE FINISH REQUIREMENTS.
- 5) CRITICAL DIMENSIONS ARE INDICATED BY:
- 6) ALL ITEMS ARE TO BE INSPECTED TO 2.5 AQL SAMPLING PLAN UNLESS OTHERWISE STATED.
- 7) ENSURE PACKAGING WILL PROVIDE ADEQUATE PROTECTION DURING TRANSPORT.
- 8) GEOMETRIC FEATURES NOT DIMENSIONED ARE CONTROLLED BY 3D MODEL.

DEPT.	NAME	DATE
SALES		
ENG.		
Q.A.		

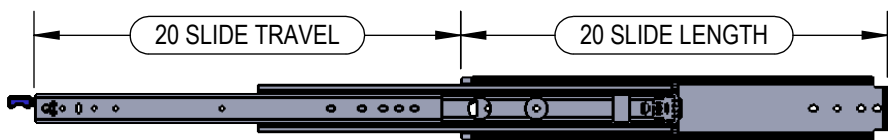

REVISIONS		
REV.	DESCRIPTION	DATE
A	INITIAL RELEASE	9/30/2015

THE INFORMATION CONTAINED IN THIS DRAWING IS THE SOLE PROPERTY OF RYADON INC. ANY REPRODUCTION IN PART OR AS A WHOLE WITHOUT THE WRITTEN PERMISSION OF RYADON INC. IS PROHIBITED.

TOLERANCES UNLESS OTHERWISE SPECIFIED: .X = ± .05 .XX = ± .03 .XXX = ± .015 X/X = ± 1/32" ANGLE = ± 1° SURFACE = ± √	DESCRIPTION: <b>20" 3600 SERIES SLIDE</b> MATERIAL: <b>STEEL</b> FINISH: <b>ZINC PLATED</b>
--	--

**RYADON INC.**

PART No. **I-DS-3600-20** REV **A**

SHEET 1 OF 1 SCALE: NTS SIZE A DRAWN BY/DATE: KAS 9/30/15

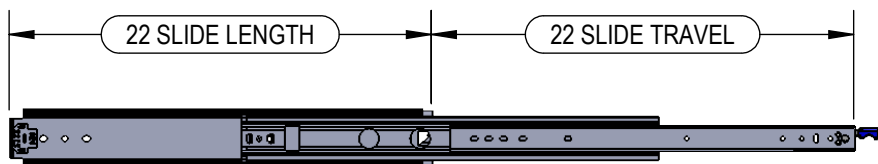
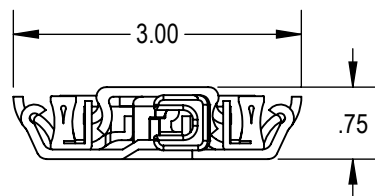
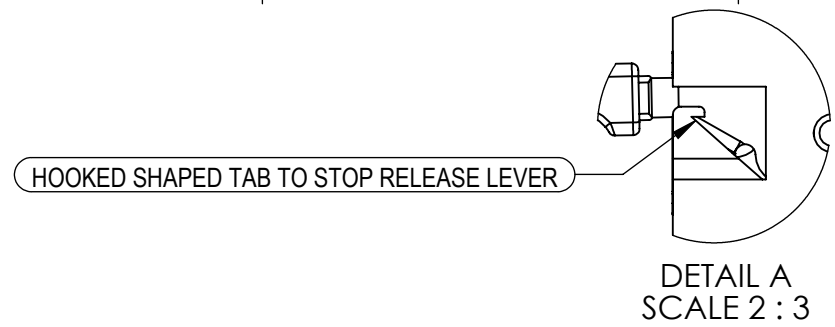
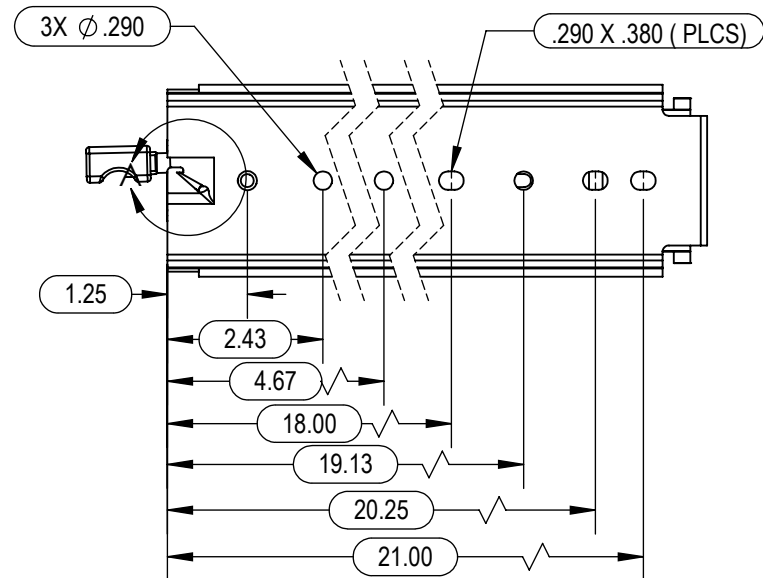
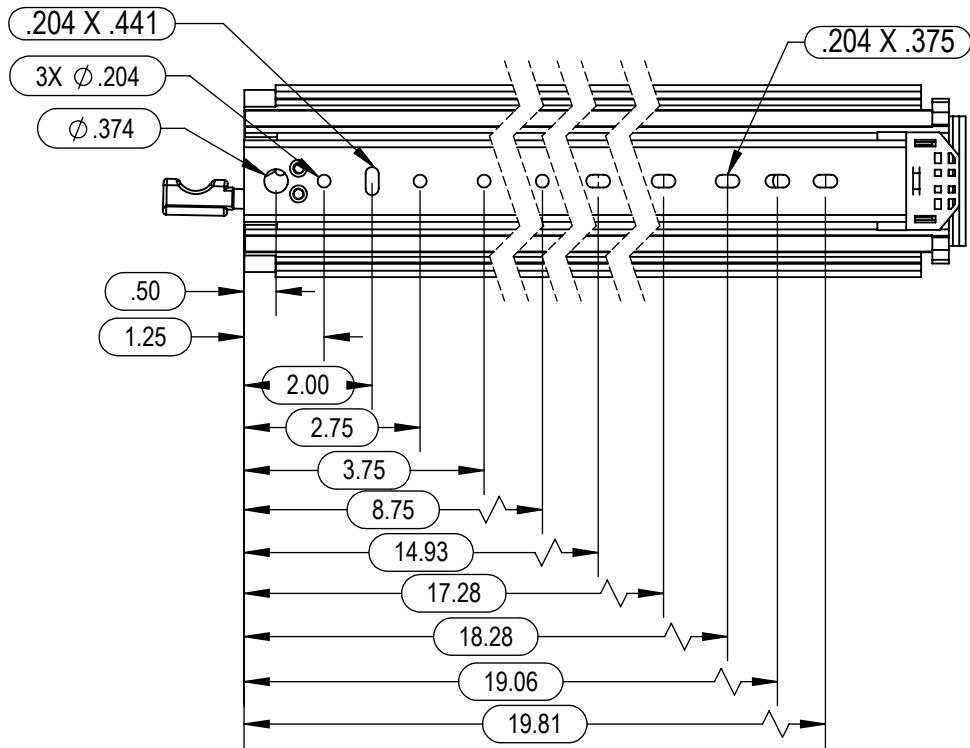

RECOMMENDED  
 INNER SLIDE MEMBER:  
 #10 MACHINE OR WOOD PAN HEAD SCREW FOR ALL THRU HOLES AND SLOTTED THRU HOLES

OUTER SLIDE MEMBER:  
 1/4 HEX BOLT, #14 PAN HEAD WOOD SCREW FOR ALL THRU HOLES AND SLOTTED THRU HOLES

**NOTES:**

- 1.) DO NOT SCALE DRAWING.
- 2.) REMOVE ALL BURRS, NO SHARP EDGES.
- 3.) MUST NOT HAVE SCRATCHES, DINGS, OR DENTS.
- 4.) PART TO BE FREE FROM SURFACE IMPERFECTIONS OTHER THAN SURFACE FINISH REQUIREMENTS.
- 5.) CRITICAL DIMENSIONS ARE INDICATED BY:
- 6.) ALL ITEMS ARE TO BE INSPECTED TO 2.5 AQL SAMPLING PLAN UNLESS OTHERWISE STATED.
- 7.) ENSURE PACKAGING WILL PROVIDE ADEQUATE PROTECTION DURING TRANSPORT.
- 8.) GEOMETRIC FEATURES NOT DIMENSIONED ARE CONTROLLED BY 3D MODEL.

THE INFORMATION CONTAINED IN THIS DRAWING IS THE SOLE PROPERTY OF RYADON INC. ANY REPRODUCTION IN PART OR AS A WHOLE WITHOUT THE WRITTEN PERMISSION OF RYADON INC. IS PROHIBITED.

REVISIONS			DEPT.	NAME	DATE
REV.	DESCRIPTION	DATE	SALES		
A	INITIAL RELEASE	07/15/14	ENG.		
TOLERANCES UNLESS OTHERWISE SPECIFIED: .X = ± .05 .XX = ± .03 .XXX = ± .015 X/X = ± 1/32" ANGLE = ± 1° SURFACE = ± $\sqrt{.125}$			<b>DESCRIPTION:</b> 22" SLIDE WITH RED LEVER <b>RYADON INC.</b>		
<b>MATERIAL:</b> STEEL <b>FINISH:</b> ZINC PLATED			<b>SIZE</b> A	<b>PART No.</b> I-DS-3600-22	<b>REV</b> A
<b>SCALE:</b> NTS			<b>SHEET 1 OF 1</b>		<b>DRAWN BY/DATE</b> KAS 07/15/14



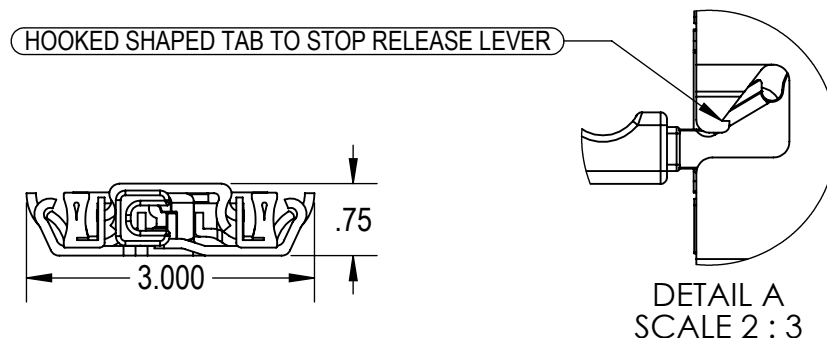
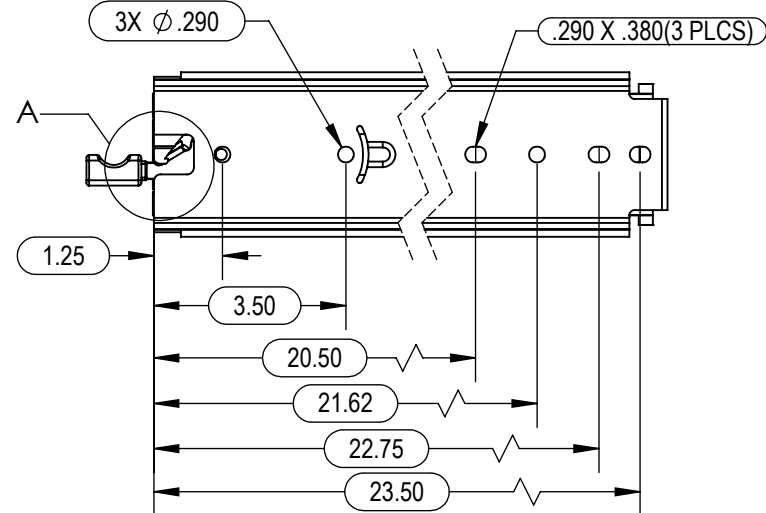
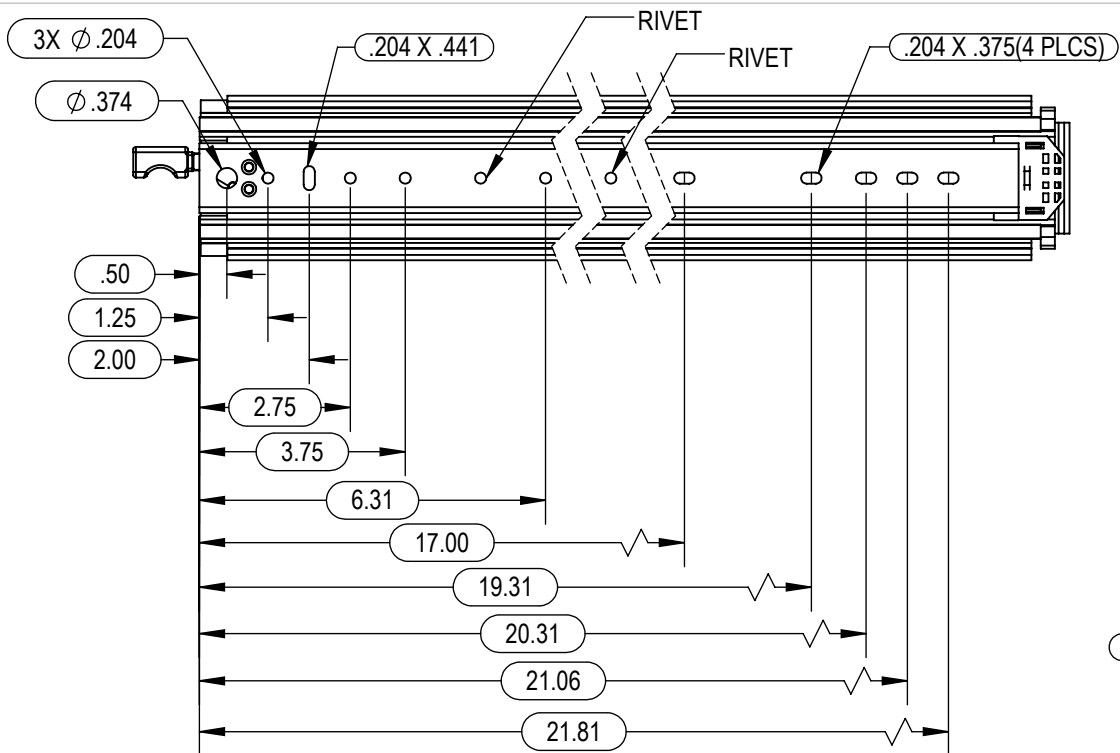

**LEFT HAND VERSION**

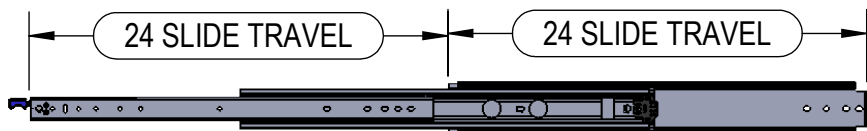

**RECOMMENDED**

**INNER SLIDE MEMBER:**

#10 MACHINE OR WOOD PAN HEAD SCREW FOR ALL THRU HOLES AND SLOTTED THRU HOLES

**OUTER SLIDE MEMBER:**

1/4 HEX BOLT, #14 PAN HEAD WOOD SCREW FOR ALL THRU HOLES AND SLOTTED THRU HOLES

**NOTES:**

- 1.) DO NOT SCALE DRAWING.
- 2.) REMOVE ALL BURRS, NO SHARP EDGES.
- 3.) MUST NOT HAVE SCRATCHES, DINGS, OR DENTS.
- 4.) PART TO BE FREE FROM SURFACE IMPERFECTIONS OTHER THAN SURFACE FINISH REQUIREMENTS.
- 5.) CRITICAL DIMENSIONS ARE INDICATED BY:
- 6.) ALL ITEMS ARE TO BE INSPECTED TO 2.5 AQL SAMPLING PLAN UNLESS OTHERWISE STATED.
- 7.) ENSURE PACKAGING WILL PROVIDE ADEQUATE PROTECTION DURING TRANSPORT.
- 8.) GEOMETRIC FEATURES NOT DIMENSIONED ARE CONTROLLED BY 3D MODEL.

THE INFORMATION CONTAINED IN THIS DRAWING IS THE SOLE PROPERTY OF RYADON INC. ANY REPRODUCTION IN PART OR AS A WHOLE WITHOUT THE WRITTEN PERMISSION OF RYADON INC. IS PROHIBITED.

REVISIONS			DEPT.	NAME	DATE
REV.	DESCRIPTION	DATE	SALES	ENG.	
A	INITIAL RELEASE	03/11/15	Q.A.		
TOLERANCES UNLESS OTHERWISE SPECIFIED: .X = ± .05 .XX = ± .03 .XXX = ± .015 X/X = ± 1/32" ANGLE = ± 1° SURFACE = ± .125/√			<b>DESCRIPTION:</b> 24" 3600 SERIES SLIDE <b>RYADON INC.</b>		
<b>MATERIAL:</b> STEEL			<b>SIZE</b> A		<b>PART No.</b> I-DS-3600-24
<b>FINISH:</b> ZINC PLATED			<b>SCALE:</b> NTS		<b>SHEET</b> 1 OF 1
			<b>DRAWN BY/DATE</b> KAS 3/11/15		<b>REV</b> A



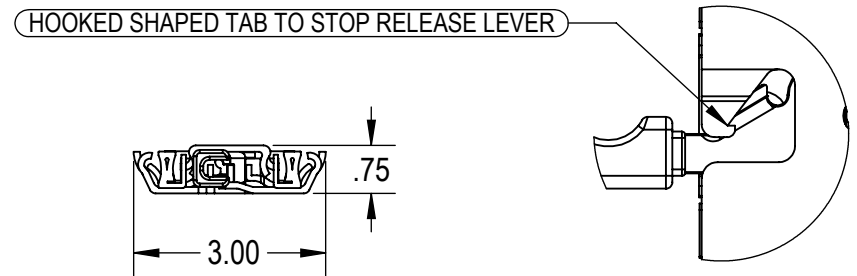
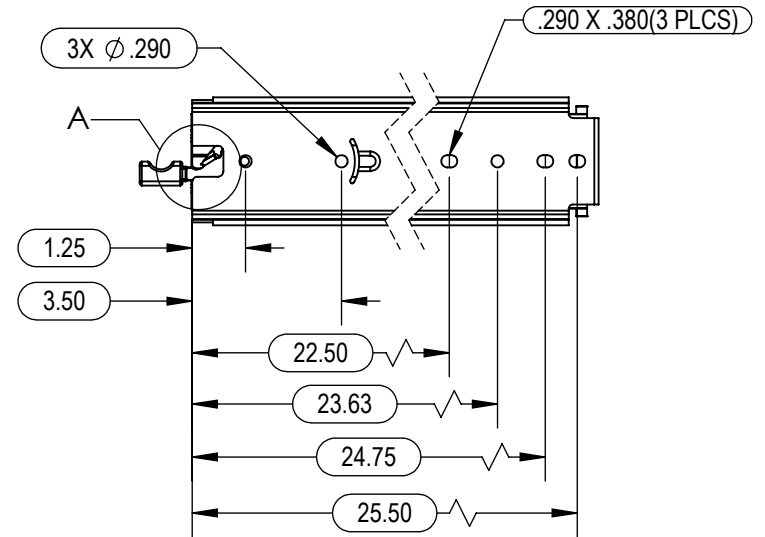
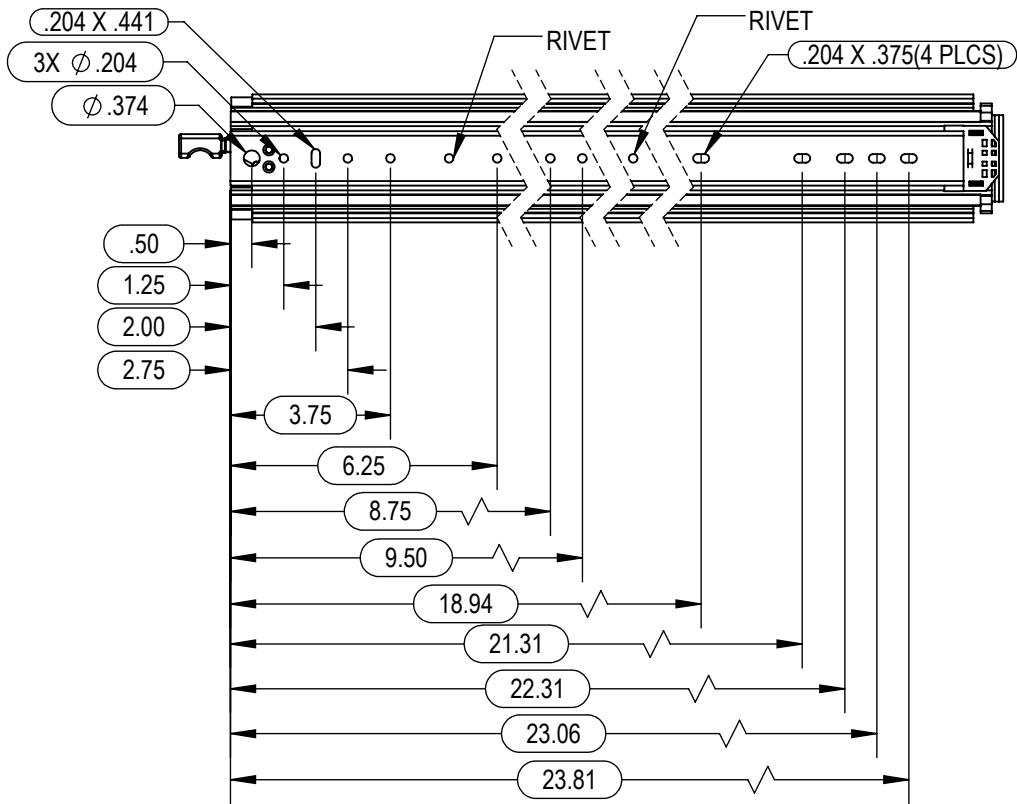

DETAIL A  
SCALE 2 : 3

LEFT HAND VERSION

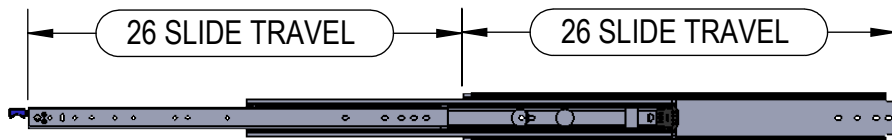

RECOMMENDED

INNER SLIDE MEMBER:

#10 MACHINE OR WOOD PAN HEAD SCREW FOR ALL THRU HOLES AND SLOTTED THRU HOLES

OUTER SLIDE MEMBER:

1/4 HEX BOLT, #14 PAN HEAD WOOD SCREW FOR ALL THRU HOLES AND SLOTTED THRU HOLES

NOTES:

- 1.) DO NOT SCALE DRAWING.
- 2.) REMOVE ALL BURRS, NO SHARP EDGES.
- 3.) MUST NOT HAVE SCRATCHES, DINGS, OR DENTS.
- 4.) PART TO BE FREE FROM SURFACE IMPERFECTIONS OTHER THAN SURFACE FINISH REQUIREMENTS.
- 5.) CRITICAL DIMENSIONS ARE INDICATED BY:
- 6.) ALL ITEMS ARE TO BE INSPECTED TO 2.5 AQL SAMPLING PLAN UNLESS OTHERWISE STATED.
- 7.) ENSURE PACKAGING WILL PROVIDE ADEQUATE PROTECTION DURING TRANSPORT.
- 8.) GEOMETRIC FEATURES NOT DIMENSIONED ARE CONTROLLED BY 3D MODEL.

THE INFORMATION CONTAINED IN THIS DRAWING IS THE SOLE PROPERTY OF RYADON INC. ANY REPRODUCTION IN PART OR AS A WHOLE WITHOUT THE WRITTEN PERMISSION OF RYADON INC. IS PROHIBITED.

REVISIONS			DEPT.	NAME	DATE
REV.	DESCRIPTION	DATE	SALES		
A	INITIAL RELEASE	03/11/15	ENG.		
			Q.A.		
TOLERANCES UNLESS OTHERWISE SPECIFIED: .X = ± .05 .XX = ± .03 .XXX = ± .015 X/X = ± 1/32" ANGLE = ± 1° SURFACE = ± .125/√			DESCRIPTION: <b>26" 3600 SERIES SLIDE</b> MATERIAL: STEEL FINISH: ZINC PLATED		
			<b>RYADON INC.</b>		
			SIZE A	PART No. I-DS-3600-26	REV A
			SCALE: NTS	SHEET 1 OF 1	DRAWN BY/DATE KAS 3/11/15



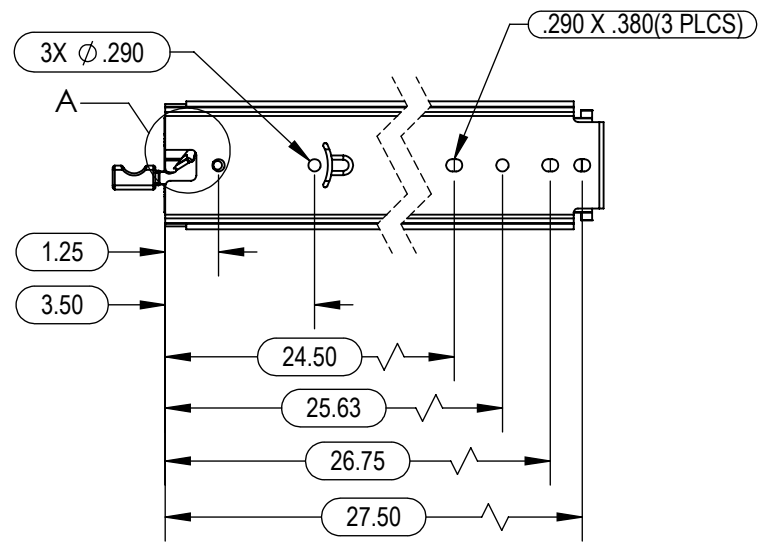
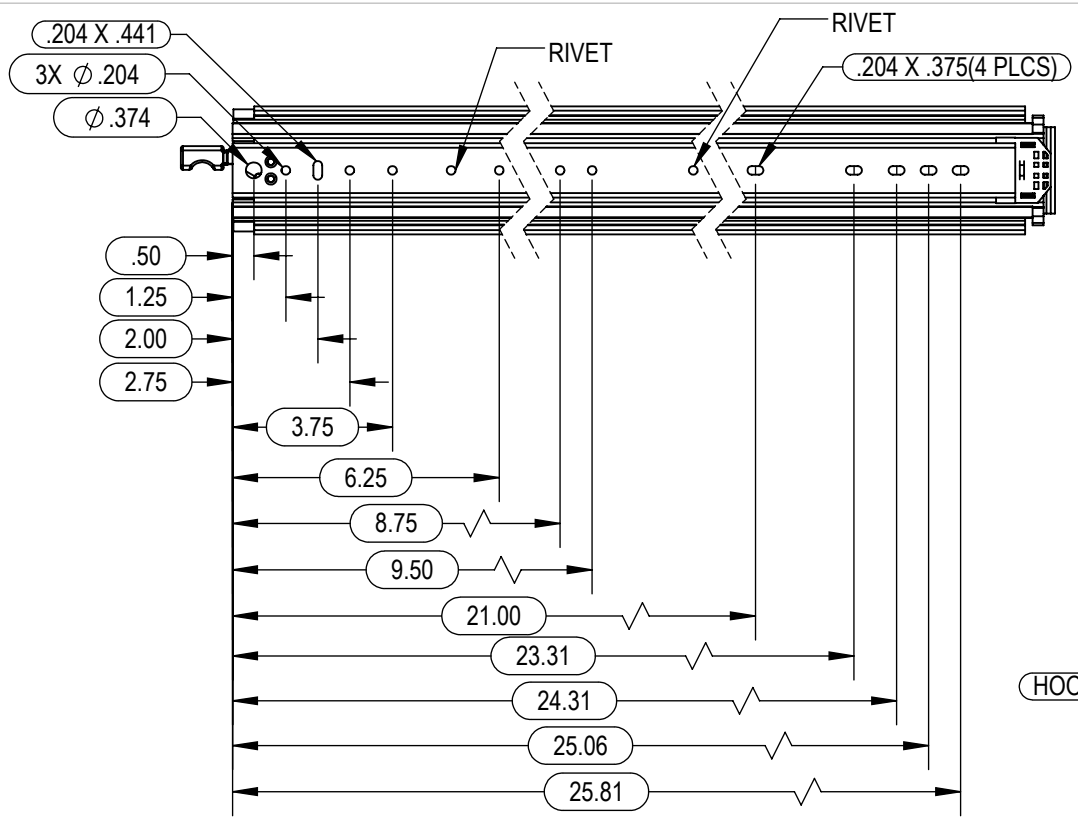

HOOKED SHAPED TAB TO STOP RELEASE LEVER

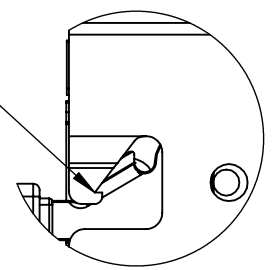
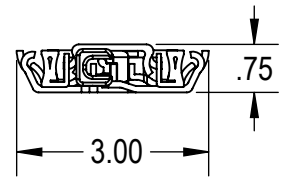

DETAIL A  
SCALE 2 : 3

LEFT HAND VERSION

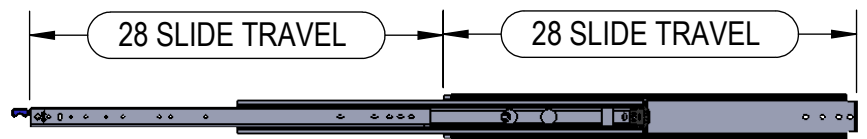

RECOMMENDED

INNER SLIDE MEMBER:

#10 MACHINE OR WOOD PAN HEAD SCREW FOR ALL THRU HOLES AND SLOTTED THRU HOLES

OUTER SLIDE MEMBER:

1/4 HEX BOLT, #14 PAN HEAD WOOD SCREW FOR ALL THRU HOLES AND SLOTTED THRU HOLES

NOTES:

- 1.) DO NOT SCALE DRAWING.
- 2.) REMOVE ALL BURRS, NO SHARP EDGES.
- 3.) MUST NOT HAVE SCRATCHES, DINGS, OR DENTS.
- 4.) PART TO BE FREE FROM SURFACE IMPERFECTIONS OTHER THAN SURFACE FINISH REQUIREMENTS.
- 5.) CRITICAL DIMENSIONS ARE INDICATED BY:
- 6.) ALL ITEMS ARE TO BE INSPECTED TO 2.5 AQL SAMPLING PLAN UNLESS OTHERWISE STATED.
- 7.) ENSURE PACKAGING WILL PROVIDE ADEQUATE PROTECTION DURING TRANSPORT.
- 8.) GEOMETRIC FEATURES NOT DIMENSIONED ARE CONTROLLED BY 3D MODEL.

THE INFORMATION CONTAINED IN THIS DRAWING IS THE SOLE PROPERTY OF RYADON INC. ANY REPRODUCTION IN PART OR AS A WHOLE WITHOUT THE WRITTEN PERMISSION OF RYADON INC. IS PROHIBITED.

REVISIONS			DEPT.	NAME	DATE
REV.	DESCRIPTION	DATE	SALES		
A	INITIAL RELEASE	03/11/15	ENG.		
			Q.A.		
TOLERANCES UNLESS OTHERWISE SPECIFIED: .X = ± .05 .XX = ± .03 .XXX = ± .015 X/X = ± 1/32" ANGLE = ± 1° SURFACE = ± .125√			DESCRIPTION: <b>28" 3600 SERIES SLIDE</b>		
MATERIAL: <b>STEEL</b>			<b>RYADON INC.</b>		
FINISH: <b>ZINC PLATED</b>			SIZE <b>A</b> PART No. <b>I-DS-3600-28</b>		
SCALE: NTS			SHEET 1 OF 1		
DRAWN BY/DATE KAS 3/11/15			REV <b>A</b>		



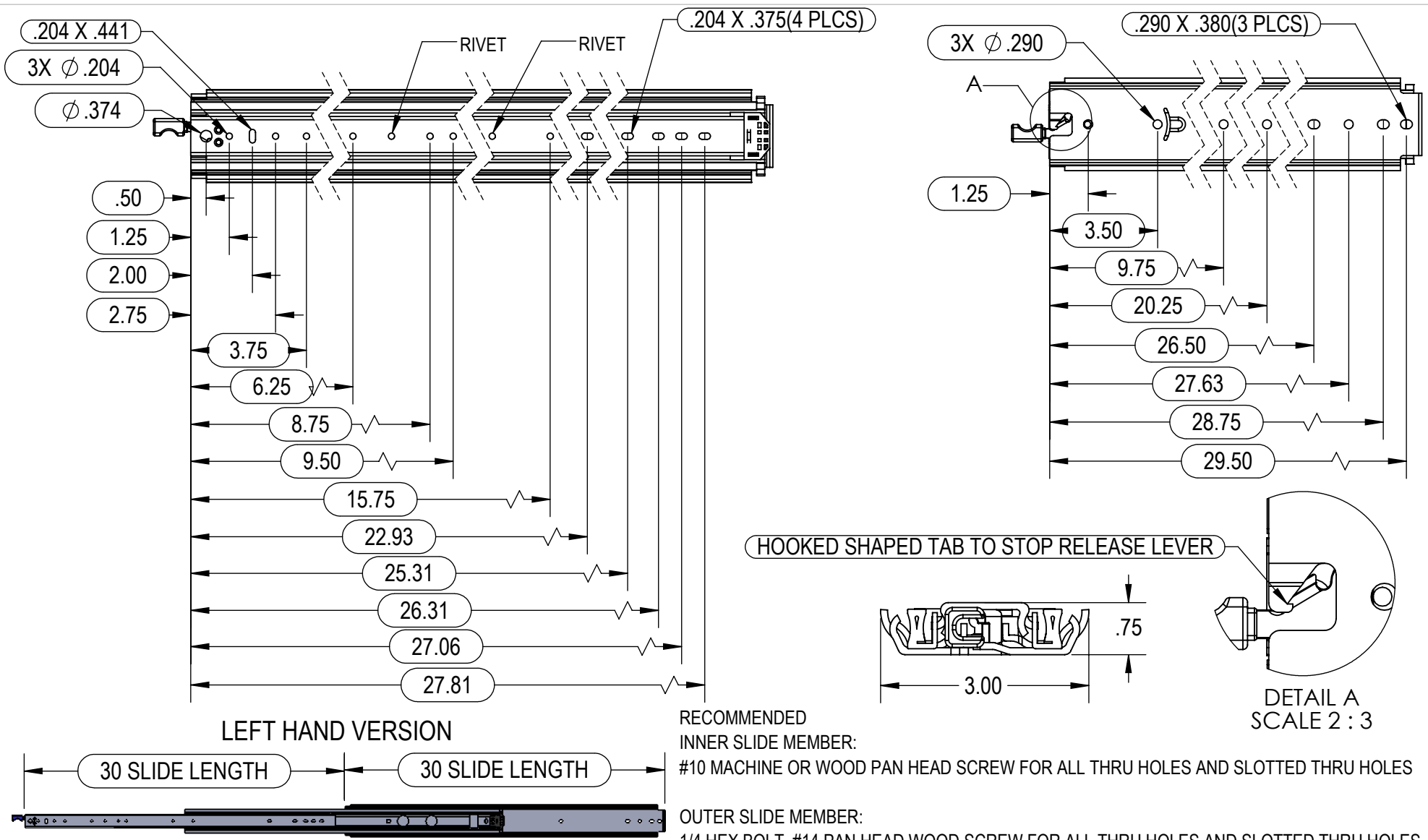

**NOTES:**

- 1.) DO NOT SCALE DRAWING.
- 2.) REMOVE ALL BURRS, NO SHARP EDGES.
- 3.) MUST NOT HAVE SCRATCHES, DINGS, OR DENTS.
- 4.) PART TO BE FREE FROM SURFACE IMPERFECTIONS OTHER THAN SURFACE FINISH REQUIREMENTS.
- 5.) CRITICAL DIMENSIONS ARE INDICATED BY:
- 6.) ALL ITEMS ARE TO BE INSPECTED TO 2.5 AQL SAMPLING PLAN UNLESS OTHERWISE STATED.
- 7.) ENSURE PACKAGING WILL PROVIDE ADEQUATE PROTECTION DURING TRANSPORT.
- 8.) GEOMETRIC FEATURES NOT DIMENSIONED ARE CONTROLLED BY 3D MODEL.

THE INFORMATION CONTAINED IN THIS DRAWING IS THE SOLE PROPERTY OF RYADON INC. ANY REPRODUCTION IN PART OR AS A WHOLE WITHOUT THE WRITTEN PERMISSION OF RYADON INC. IS PROHIBITED.

REVISIONS			DEPT.	NAME	DATE
REV.	DESCRIPTION	DATE	SALES		
A	INITIAL RELEASE	03/11/15	ENG.		
TOLERANCES UNLESS OTHERWISE SPECIFIED:			DESCRIPTION:		
.X = ± .05 .XX = ± .03 .XXX = ± .015 X/X = ± 1/32" ANGLE = ± 1° SURFACE = ± .125/√			30" 3600 SERIES SLIDE <b>RYADON INC.</b>		
MATERIAL: STEEL			SIZE A	PART No. I-DS-3600-30	REV A
FINISH: ZINC PLATED			SCALE: NTS	SHEET 1 OF 1	DRAWN BY/DATE KAS 3/11/15

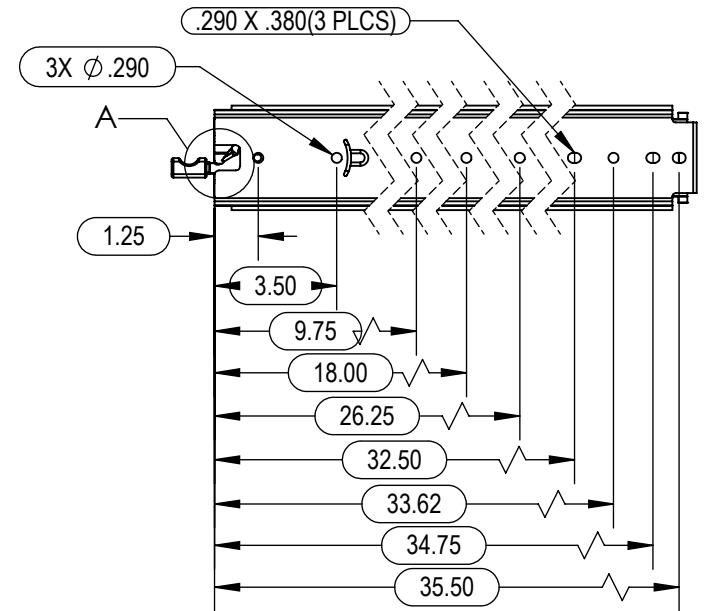
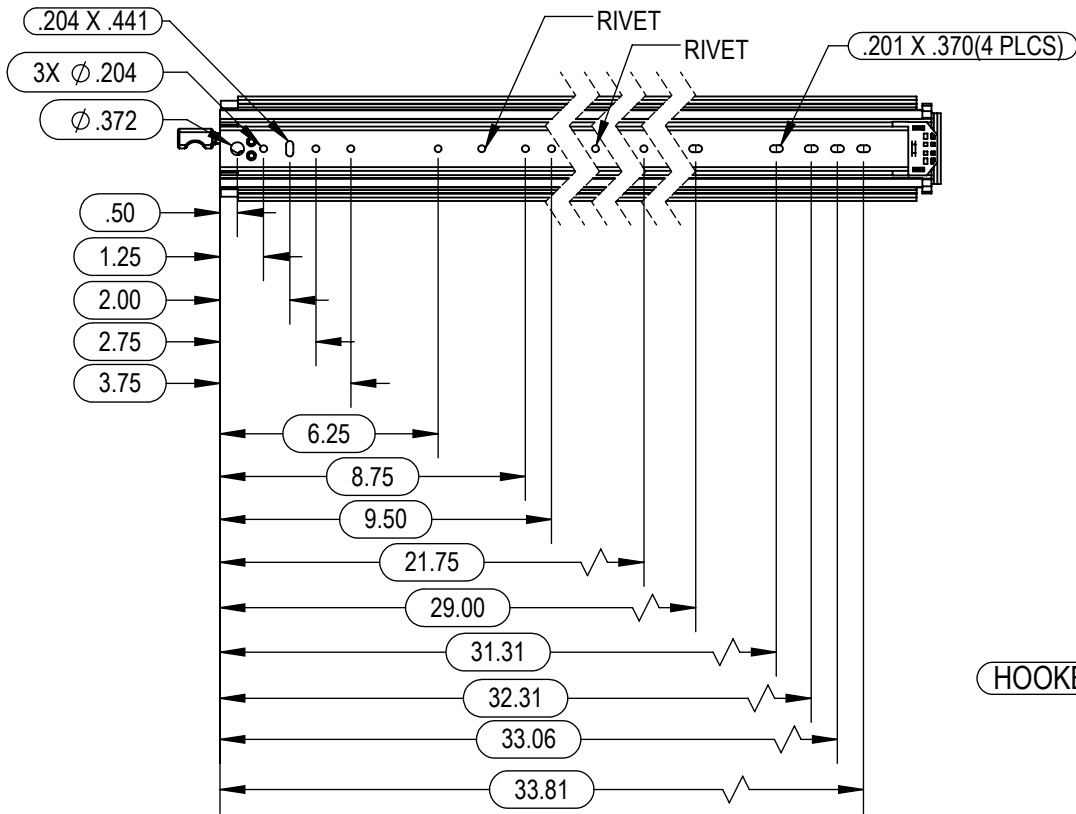

HOOKED SHAPED TAB TO STOP RELEASE LEVER

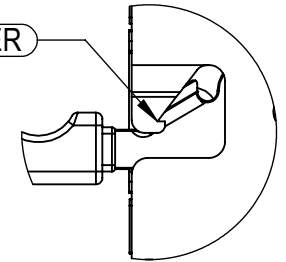
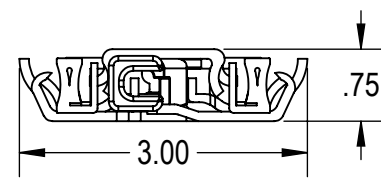

DETAIL A  
SCALE 2 : 3

LEFT HAND VERSION

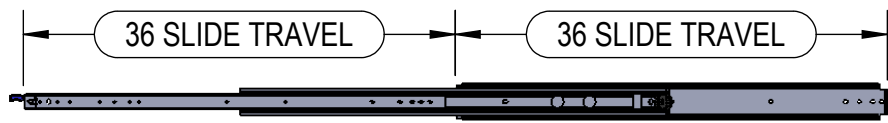

RECOMMENDED  
INNER SLIDE MEMBER:  
#10 MACHINE OR WOOD PAN HEAD SCREW FOR ALL THRU HOLES AND SLOTTED THRU HOLES  
OUTER SLIDE MEMBER:  
1/4 HEX BOLT, #14 PAN HEAD WOOD SCREW FOR ALL THRU HOLES AND SLOTTED THRU HOLES

- NOTES:**
- 1.) DO NOT SCALE DRAWING.
  - 2.) REMOVE ALL BURRS, NO SHARP EDGES.
  - 3.) MUST NOT HAVE SCRATCHES, DINGS, OR DENTS.
  - 4.) PART TO BE FREE FROM SURFACE IMPERFECTIONS OTHER THAN SURFACE FINISH REQUIREMENTS.
  - 5.) CRITICAL DIMENSIONS ARE INDICATED BY:
  - 6.) ALL ITEMS ARE TO BE INSPECTED TO 2.5 AQL SAMPLING PLAN UNLESS OTHERWISE STATED.
  - 7.) ENSURE PACKAGING WILL PROVIDE ADEQUATE PROTECTION DURING TRANSPORT.
  - 8.) GEOMETRIC FEATURES NOT DIMENSIONED ARE CONTROLLED BY 3D MODEL.

THE INFORMATION CONTAINED IN THIS DRAWING IS THE SOLE PROPERTY OF RYADON INC. ANY REPRODUCTION IN PART OR AS A WHOLE WITHOUT THE WRITTEN PERMISSION OF RYADON INC. IS PROHIBITED.

REVISIONS			DEPT.	NAME	DATE
REV.	DESCRIPTION	DATE	SALES		
A	INITIAL RELEASE	03/11/15	ENG.		
			Q.A.		
TOLERANCES UNLESS OTHERWISE SPECIFIED: .X = ± .05 .XX = ± .03 .XXX = ± .015 X/X = ± 1/32" ANGLE = ± 1° SURFACE = ± .125/√			DESCRIPTION: <b>36" 3600 SERIES SLIDE</b> MATERIAL: STEEL FINISH: ZINC PLATED		
SIZE A PART No. I-DS-3600-36			<b>RYADON INC.</b> 		
SCALE: NTS			SHEET 1 OF 1		REV A
			DRAWN BY/DATE		KAS 3/11/15

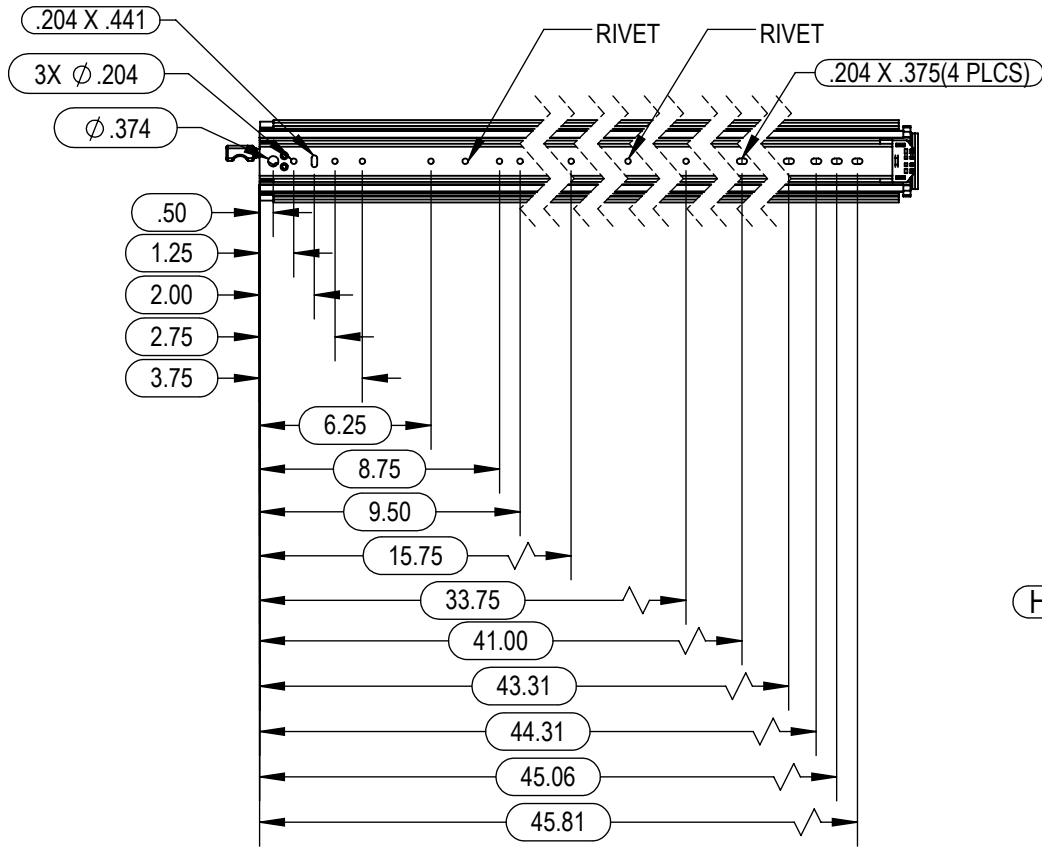

LEFT HAND VERSION

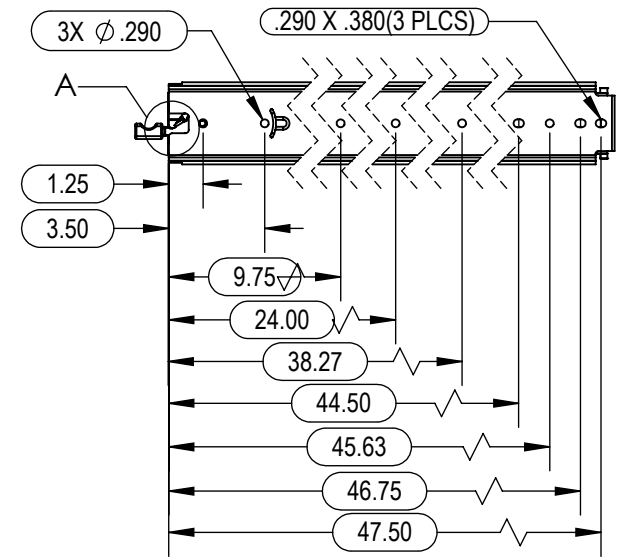
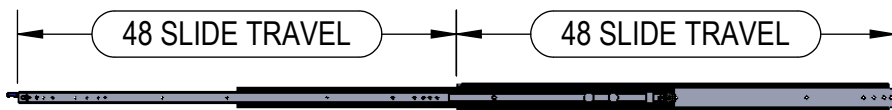

HOOKED SHAPED TAB TO STOP RELEASE LEVER

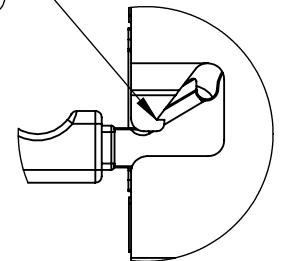
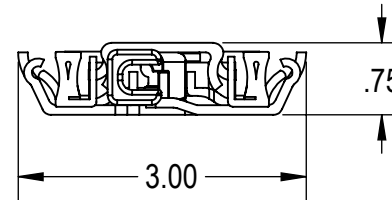

DETAIL A  
SCALE 2 : 3

RECOMMENDED

INNER SLIDE MEMBER:

#10 MACHINE OR WOOD PAN HEAD SCREW FOR ALL THRU HOLES AND SLOTTED THRU HOLES

OUTER SLIDE MEMBER:

1/4 HEX BOLT, #14 PAN HEAD WOOD SCREW FOR ALL THRU HOLES AND SLOTTED THRU HOLES

NOTES:

- 1.) DO NOT SCALE DRAWING.
- 2.) REMOVE ALL BURRS, NO SHARP EDGES.
- 3.) MUST NOT HAVE SCRATCHES, DINGS, OR DENTS.
- 4.) PART TO BE FREE FROM SURFACE IMPERFECTIONS OTHER THAN SURFACE FINISH REQUIREMENTS.
- 5.) CRITICAL DIMENSIONS ARE INDICATED BY
- 6.) ALL ITEMS ARE TO BE INSPECTED TO 2.5 AQL SAMPLING PLAN UNLESS OTHERWISE STATED.
- 7.) ENSURE PACKAGING WILL PROVIDE ADEQUATE PROTECTION DURING TRANSPORT.
- 8.) GEOMETRIC FEATURES NOT DIMENSIONED ARE CONTROLLED BY 3D MODEL.

THE INFORMATION CONTAINED IN THIS DRAWING IS THE SOLE PROPERTY OF RYADON INC. ANY REPRODUCTION IN PART OR AS A WHOLE WITHOUT THE WRITTEN PERMISSION OF RYADON INC. IS PROHIBITED.

REVISIONS			DEPT.	NAME	DATE
REV.	DESCRIPTION	DATE	SALES		
A	INITIAL RELEASE	03/11/15	ENG.		
			Q.A.		
TOLERANCES UNLESS OTHERWISE SPECIFIED: .X = ± .05 .XX = ± .03 .XXX = ± .015 X/X = ± 1/32" ANGLE = ± 1° SURFACE = ± .125/√			DESCRIPTION: <b>48" 3600 SERIES SLIDE</b> MATERIAL: STEEL FINISH: ZINC PLATED		
SIZE A PART No. I-DS-3600-48			<b>RYADON INC.</b> 		
SCALE: NTS			SHEET 1 OF 1		REV A
			DRAWN BY/DATE		KAS 3/11/15

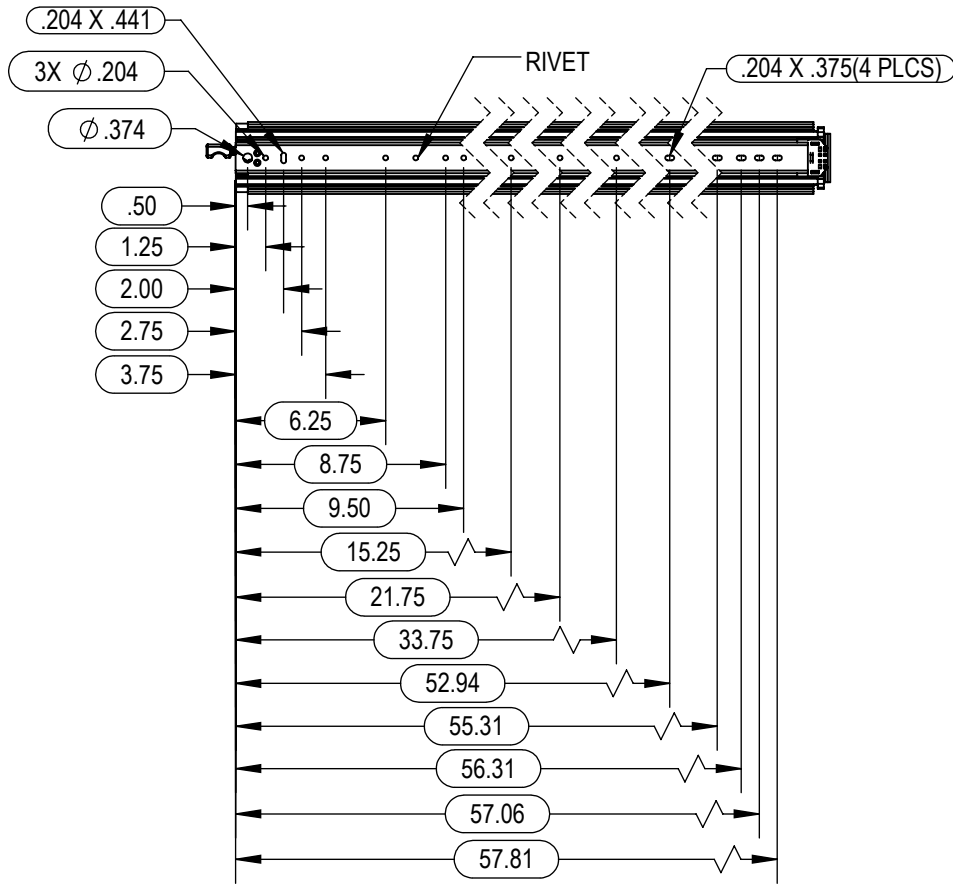

LEFT HAND VERSION

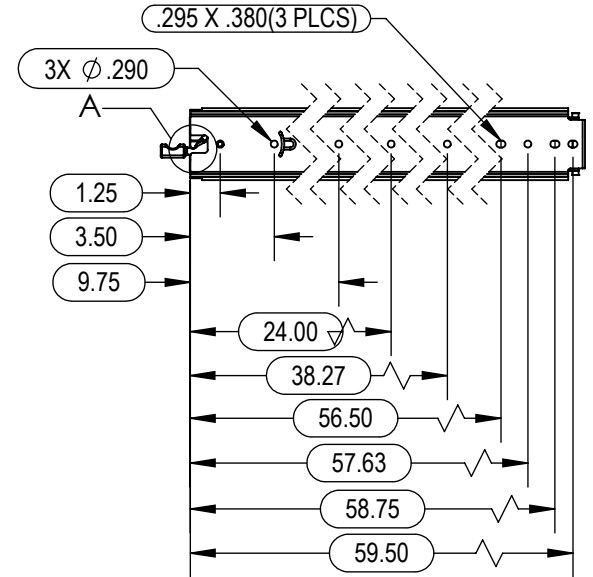
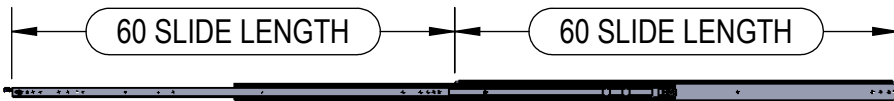

HOOKED SHAPED TAB TO STOP RELEASE LEVER

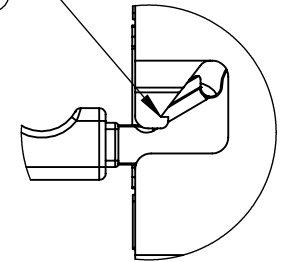
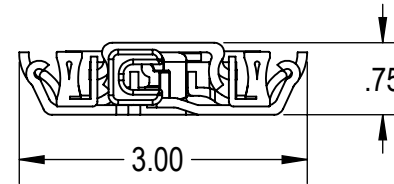

DETAIL A  
SCALE 2 : 3

RECOMMENDED

INNER SLIDE MEMBER:

#10 MACHINE OR WOOD PAN HEAD SCREW FOR ALL THRU HOLES AND SLOTTED THRU HOLES

OUTER SLIDE MEMBER:

1/4 HEX BOLT, #14 PAN HEAD WOOD SCREW FOR ALL THRU HOLES AND SLOTTED THRU HOLES

NOTES:

- 1.) DO NOT SCALE DRAWING.
- 2.) REMOVE ALL BURRS, NO SHARP EDGES.
- 3.) MUST NOT HAVE SCRATCHES, DINGS, OR DENTS.
- 4.) PART TO BE FREE FROM SURFACE IMPERFECTIONS OTHER THAN SURFACE FINISH REQUIREMENTS.
- 5.) CRITICAL DIMENSIONS ARE INDICATED BY:
- 6.) ALL ITEMS ARE TO BE INSPECTED TO 2.5 AQL SAMPLING PLAN UNLESS OTHERWISE STATED.
- 7.) ENSURE PACKAGING WILL PROVIDE ADEQUATE PROTECTION DURING TRANSPORT.
- 8.) GEOMETRIC FEATURES NOT DIMENSIONED ARE CONTROLLED BY 3D MODEL.

THE INFORMATION CONTAINED IN THIS DRAWING IS THE SOLE PROPERTY OF RYADON INC. ANY REPRODUCTION IN PART OR AS A WHOLE WITHOUT THE WRITTEN PERMISSION OF RYADON INC. IS PROHIBITED.

REVISIONS			DEPT.	NAME	DATE
REV.	DESCRIPTION	DATE	SALES		
A	INITIAL RELEASE	03/11/15	ENG.		
			Q.A.		
TOLERANCES UNLESS OTHERWISE SPECIFIED: .X = ± .05 .XX = ± .03 .XXX = ± .015 X/X = ± 1/32" ANGLE = ± 1° SURFACE = ± $\sqrt{.125}$			DESCRIPTION: <b>60" 3600 SERIES SLIDE</b> MATERIAL: STEEL FINISH: ZINC PLATED		
RYADON INC.			SIZE A PART No. I-DS-3600-60 REV A		
SCALE: NTS			SHEET 1 OF 1		
DRAWN BY/DATE KAS 3/11/15					